

pdp11

**M9312
bootstrap/terminator
module technical
manual**

digital

**M9312
bootstrap/terminator
module technical
manual**

1st Edition, July 1978
2nd Edition (Rev), October 1979

Copyright © 1978, 1979 by Digital Equipment Corporation
All Rights Reserved.

The material in this manual is for informational purposes and is subject to change without notice.

Digital Equipment Corporation assumes no responsibility for any errors which may appear in this manual.

Printed in U.S.A.

This document was set on DIGITAL's DECset-8000 computerized typesetting system.

The following are trademarks of Digital Equipment Corporation, Maynard, Massachusetts;

DIGITAL	DECsystem-10	MASSBUS
DEC	DECSYSTEM-20	OMNIBUS
PDP	DIBOL	OS/8
DECUS	EDUSYSTEM	RSTS
UNIBUS	VAX	RSX
	VMS	IAS

CONTENTS

	Page
CHAPTER 1 INTRODUCTION	
1.1 GENERAL DESCRIPTION.....	1-1
1.1.1 Scope	1-1
1.1.2 Related Documentation	1-3
1.2 DEFINITION OF TERMS	1-3
1.3 PHYSICAL DESCRIPTION	1-3
1.4 ELECTRICAL SPECIFICATIONS.....	1-3
1.4.1 External Electrical Interfaces.....	1-3
1.4.2 Electrical Prerequisites	1-4
1.4.3 Timing	1-5
1.4.4 Operational Environmental Specifications.....	1-6
1.5 INSTALLATION.....	1-6
1.5.1 Power-Up Boot Enable.....	1-7
1.5.2 Boot Selection	1-7
1.5.3 External Boot Switch.....	1-7
CHAPTER 2 HARDWARE DESCRIPTION	
2.1 GENERAL.....	2-1
2.2 ROM MEMORY	2-1
2.2.1 ROM Specifications	2-2
2.2.2 ROM Format.....	2-2
2.2.2.1 ROM Header	2-2
2.2.3 ROM Data.....	2-3
2.2.3.1 ROM Data Transfer	2-3
2.2.3.2 ROM Data Organization.....	2-3
2.2.4 Requirements for new ROMs and Uses of the M9312	2-3
2.3 POWER-UP SEQUENCE.....	2-3
2.4 POWER-UP BOOTING LOGIC.....	2-5
2.4.1 Power-Up and Power-Down.....	2-6
2.4.2 Processor Reads New Program Counter	2-8
2.4.3 Processor Reads New Status Word.....	2-8
2.4.4 Power-Up Boot Enable Switch	2-8
2.5 EXTERNAL BOOT CIRCUIT	2-8
2.6 POWER-UP TRANSFER DETECTION LOGIC.....	2-8
2.7 POWER-UP CLEAR	2-8
2.8 ADDRESS DETECTION LOGIC	2-11
2.8.1 M9312 Address Space.....	2-11
2.8.2 Memory Access Constraints	2-11
2.8.3 LO ROM ENA H Jumper	2-11
2.9 ADDRESS OFFSET SWITCH BANK.....	2-13
2.10 M9312 TERMINATOR.....	2-14

CONTENTS (Cont)

	Page
CHAPTER 3	CONSOLE EMULATOR
3.1	GENERAL.....3-1
3.2	USING THE CONSOLE EMULATOR.....3-1
3.2.1	Successive Operations.....3-2
3.2.1.1	Examine.....3-2
3.2.1.2	Deposit3-3
3.2.1.3	Alternate Deposit-Examine Operations3-3
3.2.1.4	Alternate Examine-Deposit Operations3-3
3.2.2	Limits of Operation3-3
3.3	BOOTSTRAPS STARTED FROM THE CONSOLE EMULATOR3-3
3.3.1	Booting the High-Speed Reader Using the Console Emulator3-4
3.3.2	Booting a Disk Using the Console Emulator3-5
3.4	RECOVERING FROM ERRORS IN THE CONSOLE EMULATOR ROUTINE.....3-5
CHAPTER 4	BOOTSTRAPPING
CHAPTER 5	EXTENDED ADDRESSING
5.1	GENERAL.....5-1
5.2	VIRTUAL AND PHYSICAL ADDRESSES5-1
5.3	ADDRESS MAPPING WITHOUT MEMORY MANAGEMENT5-1
5.4	ADDRESS MAPPING WITH MEMORY MANAGEMENT.....5-1
5.5	CREATION OF A VIRTUAL ADDRESS.....5-1
5.6	CONSTRAINTS5-4
CHAPTER 6	DIAGNOSTICS
6.1	GENERAL.....6-1
6.2	DIAGNOSTICS.....6-1
6.3	DIAGNOSTICS (PDP-11/60 AND 11/70).....6-5
APPENDIX A	M9312 JUMPERS
APPENDIX B	M9312 ROMs
APPENDIX C	M9312 ADDRESS OFFSET SWITCH BANK
APPENDIX D	M9312 FASTON TAB CONNECTIONS
APPENDIX E	CROSS REFERENCE AND IDENTIFICATION TABLES
APPENDIX F	DIAGNOSTIC AND CONSOLE EMULATOR ROMS

FIGURES

Figure No.	Title	Page
1-1	M9312 Bootstrap/Terminator Module.....	1-2
1-2	M9312 Timing Constraints.....	1-5
2-1	ROM Segregation	2-1
2-2	ROM Data Transfer.....	2-4
2-3	Power-Down/Power-Up Sequence.....	2-5
2-4	Power-Up Boot Logic	2-6
2-5	Address Generation Logic.....	2-7
2-6	External Boot Logic	2-9
2-7	External Boot Timing	2-10
2-8	Power-Up Transfer Detection Logic.....	2-10
2-9	Power-Up Clear Circuitry.....	2-11
2-10	Address Detection Logic	2-12
2-11	Address Offset Switch Bank.....	2-13

TABLES

Table No.	Title	Page
1-1	Related Documentation	1-3
1-2	M9312 Pin Assignments	1-4
2-1	ROM Data Organization	2-3
3-1	Console Emulator Switch Requirements.....	3-1
3-2	Boot Command Codes	3-4
3-3	Deposit Errors: Useful Examples.....	3-6
5-1	Unibus Address Assignments	5-2
5-2	Relocation Constants	5-2
A-1	Jumper Explanation	A-1
A-2	Jumper Configurations.....	A-2
B-1	Boot ROM Installation Order.....	B-1
C-1	ROM P/N 23-751A9	C-2
C-2	ROM P/N 23-752A9	C-3
C-3	ROM P/N 23-753A9	C-4
C-4	ROM P/N 23-761A9	C-5
C-5	ROM P/N 23-755A9	C-6
C-6	ROM P/N 23-756A9	C-7
C-7	ROM P/N 23-757A9	C-8
C-8	ROM P/N 23-758A9	C-9
C-9	ROM P/N 23-759A9	C-10
C-10	ROM P/N 23-760A9	C-11
C-11	ROM P/N 23-811A9	C-12
C-12	ROM P/N 23-764A9	C-13
C-13	ROM P/N 23-765A9	C-14

TABLES (Cont)

Table No.	Title	Page
D-1	Faston Tab Description	D-1
D-2	Faston Tab Substitution.....	D-1
E-1	Cross Reference ROM P/N to ROM Table Number.....	E-1
E-2	Cross Reference Device to Controller	E-2
E-3	ROM Identification.....	E-3
F-1	Console Switch Register Settings for Diagnostic ROM	F-1
F-2	Switch Settings for ASCII Console and Diagnostic ROM	F-2

CHAPTER 1 INTRODUCTION

1.1 GENERAL DESCRIPTION

The M9312 Bootstrap/Terminator Module (Figure 1-1) contains a complete set of Unibus termination resistors along with 512 words of read only memory (ROM) that can be used for diagnostic routines, the console emulator routine, and bootstrap programs. Twelve jumpers (W-1 through W-12) are provided to allow compatibility with any Unibus PDP-11 system. Paragraph 1.6 outlines the use of these jumpers. Five sockets on the M9312 allow the user to interchange ROMs, enabling the module to be used with any Unibus PDP-11 system and boot any peripheral device by simply adding or changing ROMs. One socket is solely used for a diagnostic ROM (PDP-11/60 and 11/70 systems) or a ROM which contains the console emulator routine and diagnostics for all other PDP-11 systems. The other four sockets accept ROMs which contain bootstrap programs. One or two bootstrap programs may be contained in a particular ROM; however, some devices may require two or more ROMs to contain their particular bootstrap programs. ROM placement is outlined in Appendix B.

Diagnostics, bootstrap programs, and the console emulator routine are all selectable through the Address Offset Switch Bank on the M9312 (Paragraph 2.9). Appendix C shows the necessary switch configurations and addresses for various M9312 routines. These switch settings and addresses depend on the particular socket the ROMs are placed in. M9312 routines may be initiated in the following ways:

1. *External boot switch.* This switch is connected to the module via Faston tabs TP1 and TP2. The Address Offset Switch Bank is used to select various M9312 routines.
2. *System power-up.* This feature is enabled or disabled via switch S1-2. Again the Address Offset Switch Bank is used to select various M9312 routines.
3. *Programmer console load address and start sequence.* The programmer loads the starting address of a particular routine found in Appendix C.

NOTE

When the programmer console load address and start sequence is used to start the console emulator routine, the Address Offset Switch Bank setting determines whether or not diagnostics are run.

1.1.1 Scope

This manual is designed to provide DIGITAL Field Service and customer maintenance personnel with sufficient installation and operation information to install and maintain the M9312 Bootstrap/Terminator Module.

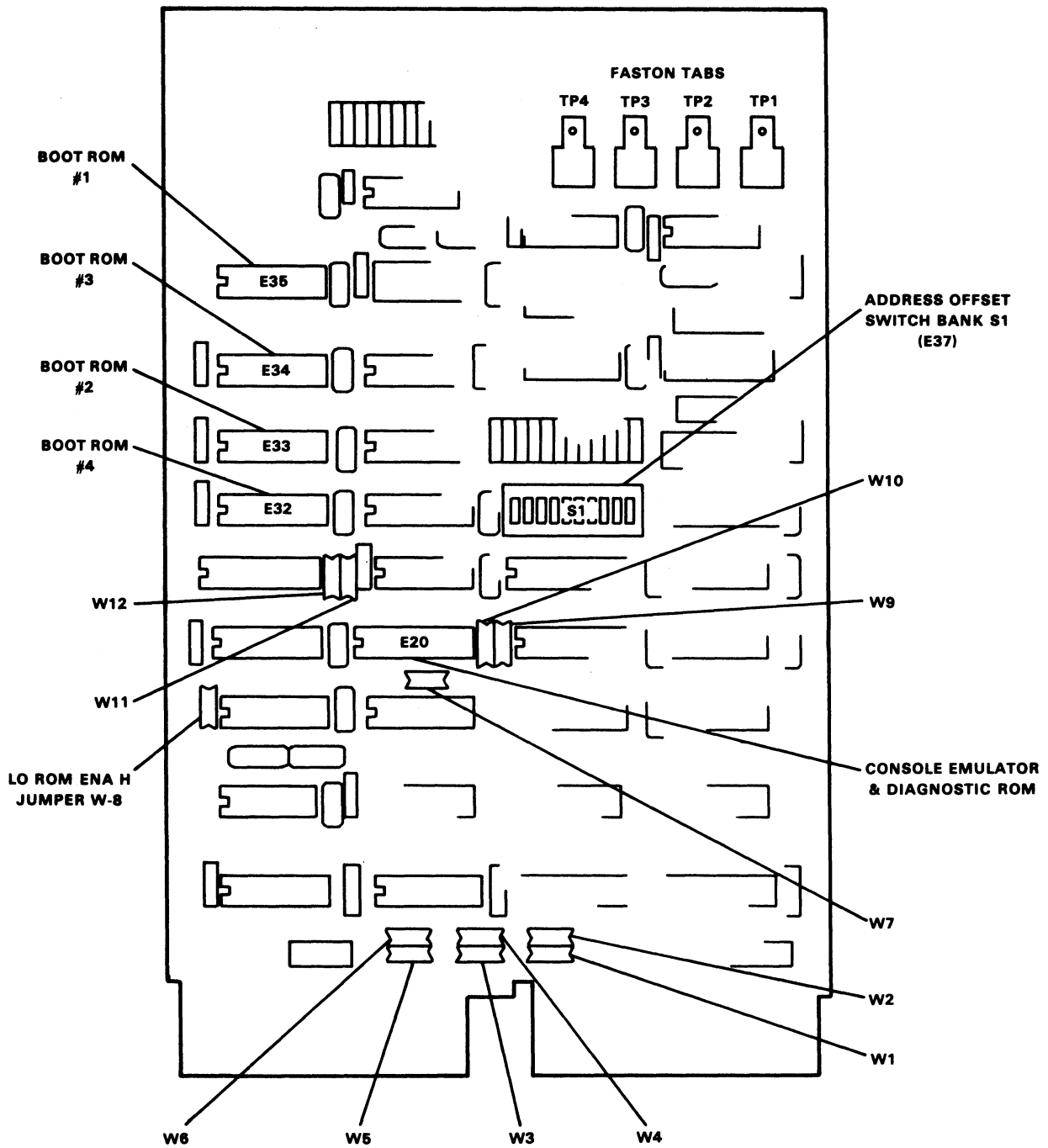

MA-0900

Figure 1-1 M9312 Bootstrap/Terminator Module

1.1.2 Related Documentation

Table 1-1 lists related documentation which supplements the information in this manual.

Table 1-1 Related Documentation

Title	Document Number	Media*
PDP-11 Processor Handbooks		Hard copy
PDP-11/34 User's Guide	EK-11034-UG-001	Hard copy
PDP-11/04 User's Guide	EK-1104-OP-002	Hard copy
Drawing Directory	B-DD-M9312-00	Microfiche

*Hard copy documents can be ordered from: Digital Equipment Corporation, 444 Whitney Street, Northboro, MA 01532, Attention: Communication Services (NR2/M15), Customer Services Section.

For information concerning microfiche libraries, contact: Digital Equipment Corporation, Micropublishing Group, PK3-2/T12, 129 Parker Street, Maynard, MA 01754.

1.2 DEFINITION OF TERMS

Bootstrap Program

A bootstrap program is any program which loads another (usually larger) program into computer memory from a peripheral device.

Bootstrap

Bootstrap and bootstrap programs are used interchangeably.

Boot

Initiate execution of a bootstrap program.

1.3 PHYSICAL DESCRIPTION

The M9312 is a double-height extended module [21.6 × 14 cm (8-1/2 × 5-1/2 in)] which plugs into the A and B terminator slots on the PDP-11 backplane. External connections are made via four Faston tabs (TP1, TP2, TP3, TP4) provided at the handle end of the module.

1.4 ELECTRICAL SPECIFICATIONS

Power Consumption +5 Vdc ± 5 percent at 1.5 A typical

Electrical Interfaces The Unibus interface is standard using 8837 and 8640 receivers, 8881 drivers, and 8641 transceivers.

1.4.1 External Electrical Interfaces

The external interface consists of four Faston tabs (TP1, TP2, TP3, and TP4) provided at the handle end of the module. These inputs were designed to operate from either a mechanical switch or a TTL output (standard or open collector). Operation from TTL outputs is restricted to circuits inside the standard DIGITAL enclosure having the same logic reference as the M9312. With mechanical switches or TTL outputs, returns (TP2 and TP3) must be used. All inputs have overvoltage protection for up to ±16 V continuous; remote switch operation may require additional protection. When remote switch operation is used, the switch should be electrically isolated from the remote device. Both signal inputs (TP1 and TP4) have filtering and do not recognize an active input (below threshold voltage) until the end of a 10 to 18 μs delay, with any interruptions resetting the delay. The threshold range is between +0.45 and +0.75 Vdc to logic reference. The following is a description of each input.

- TP1 Boot signal input. For positive or negative inputs, represents a 1000-ohm load in series with a forward biased diode to logic reference, and a 20,000-ohm pull-up. Switch bounce noise must not exceed 70 ms. Triggering is disabled for a maximum of 8 ms, starting when the M9312 power supply voltage rises from less than 3.0 V to greater than 4.5 V.
- TP2 Boot signal return. Represents a 1000-ohm load to logic reference.
- TP3 Power-up boot enable return. Represents a 1000-ohm load to logic reference.
- TP4 Power-up boot enable input. For positive or negative inputs, represents a 1000-ohm load in series with a forward-biased diode to logic reference, and a 20,000-ohm pull-up. This input must remain either a logical 1 or 0 for the entire power-up sequence.

1.4.2 Electrical Prerequisites

Power and Ground Pinouts

+5 Vdc: Pins AA2, BA2

GND: Pins AC2, AT1, BC2, BT1

(Refer to Table 1-2 for pin assignments.)

Table 1-2 M9312 Pin Assignments

Pin	Signal	Pin	Signal
AA1	BUS INIT L	BA1	SPARE
AA2	POWER (+5 V)	BA2	POWER (+5 V)
AB1	BUS INTR L	BB1	SPARE
AB2	TEST POINT	BB2	TEST POINT
AC1	BUS D00 L	BC1	BUS BR5 L
AC2	GROUND	BC2	GROUND
AD1	BUS D02 L	BD1	*W-6 IN: BUF VECTOR L
AD2	BUS D01 L		W-6 OUT: BAT BACKUP +5 V
AE1	BUS D04 L	BD2	BUS BR4 L
AE2	BUS D03 L	BE1	INT* SSYN
AF1	BUS D06 L	BE2	PAR: DET
AF2	BUS D05 L	BF1	BUS AC LO L
AH1	BUS D08 L	BF2	BUS DC LO L
AH2	BUS D07 L	BH1	BUS A01
AJ1	BUS D10 L	BH2	BUS A00 L
AJ2	BUS D09 L	BJ1	BUS A03 L
AK1	BUS D12 L	BJ2	BUS A02 L
AK2	BUS D11 L	BK1	BUS A05 L
AL1	BUS D14 L	BK2	BUS A04 L
AL2	BUS D13 L	BL1	BUS A07 L
AM1	BUS PA L	BL2	BUS A06 L
AM2	BUS D15 L	BM1	BUS A09 L
AN1	P1	BM2	BUS A08 L
AN2	BUS PB L	BN1	BUS A11 L
AP1	P0	BN2	BUS A10 L

*W-6 must be out for operation in a modified Unibus slot.

Table 1-2 M9312 Pin Assignments (Cont)

Pin	Signal	Pin	Signal
AP2	BUS BBSY L	BP1	BUS A13 L
AR1	BAT BACKUP +15 V	BP2	BUS A12 L
AR2	BUS SACK L	BR1	BUS A15 L
AS1	BAT BACKUP -15 V	BR2	BUS A14 L
AS2	BUS NPR L	BS1	BUS A17 L
AT1	GROUND	BS2	BUS A16 L
AT2	BUS BR7 L	BT1	GROUND
AU1	+20 V	BT2	BUS C1 L
AU2	BUS BR6 L	BU1	BUS SSYN L
AV1	+20 V	BU2	BUS C0 L
AV2	+20 V	BV1	BUS MSYN L
		BV2	-5 V

1.4.3 Timing

Figure 1-2 shows important timing constraints for the M9312. Values shown are typical.

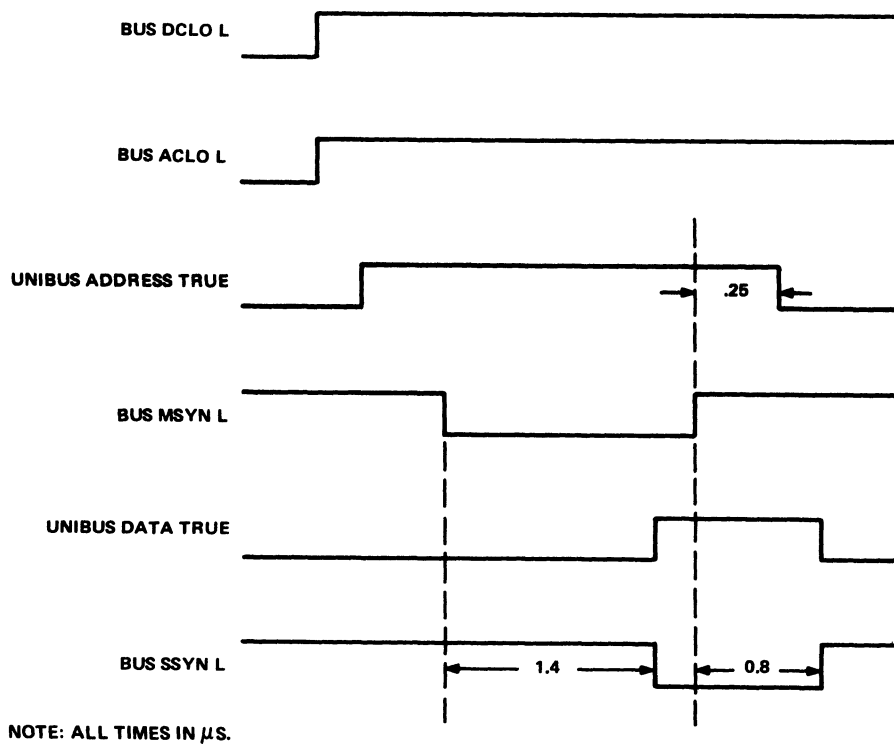

MA-0912

Figure 1-2 M9312 Timing Constraints

1.4.4 Operational Environmental Specifications

Operating Temperature Range	5° C (41° F) to 50° C (122° F)
Storage Temperature Range	-40° C (-40° F) to 66° C (151° F)
Relative Humidity	10 percent or less to 95 percent with maximum wet bulb of 32° C (90° F) and minimum dew point of 2° C (36° F).

1.5 INSTALLATION

As a universal bootstrap/terminator module, the M9312 in its various configurations can be adapted by the user to meet a variety of boot requirements and system configurations. The following guidelines should be used when installing the module.

1. System power should be turned off.
2. When a M9312 is used no other bootstrap module, such as the M9301, may be used, and only one M9312 can be used in any given PDP-11 system.
3. In PDP-11/04, 11/34, and 11/34A systems without battery backup, TP4 should not be connected to the processor's power supply battery status signals unless boots on all power restarts are desired.
4. On PDP-11 systems containing a Unibus repeater, the M9312 must be installed on the processor side of the repeater.
5. Refer to Paragraphs 1.5.1 and 1.5.3 for power-up boot enable and external boot switches if they are to be used in the system.
6. In PDP-11 systems that have grant pull-up resistors in the processor module (PDP-11/04, 11/34 and 11/34A) and use the M9312 as the terminator for the processor end, jumpers W-1 through W-5 must be out. All other processors require W-1 through W-5 to be in.
7. Jumper W-6 should be in only when the M9312 is used with PDP-11/55, 11/60, and 11/70 systems that support push-button boot.
8. Jumper W-7 must be in for use in all PDP-11 systems.
9. For PDP-11 systems with at least one peripheral device whose Unibus address lies between 765000_g and 765776_g, jumper W-8 should be in. This prevents the M9312 from responding to these addresses.
10. When the M9312 is used with a PDP-11/60 processor, jumpers W-9 and W-10 must be out, and jumpers W-11 and W-12 must be in. For all other current PDP-11 systems, jumpers W-9 and W-10 must be in and W-11 and W-12 must be out.
11. Appendix C should be consulted for the switch settings (S1-1 through S1-10) required for various boot configurations.
12. Bootstrap ROM installation must be sequential beginning with ROM location 1 (Figure 1-1), for all PDP-11 systems except the PDP-11/60, whether or not the console emulator routine is used.

13. In PDP-11/60 systems, when only one boot ROM is used it must be installed in location 2. If bootstraps are to be started from the console emulator routine, locations 1 and 2 must both contain ROMs. Additional ROMs must be installed first in location 3 and then in location 4 (Figure 1-1).

1.5.1 Power-Up Boot Enable

Automatic booting on power-up can be enabled or disabled using the power-up boot enable switch (S1-2). If this switch is set to the OFF position, the processor will execute its power-up routine normally, obtaining a new program counter (PC) from memory location 24_8 and a new processor status word (PSW) from location 26_8 . When the switch is in the ON position during a power-up, the processor will obtain its new PC and PSW from locations 773024_8 and 773026_8 respectively. The address of the Offset Switch Bank (S1-1 and S1-3 through S1-10) is 773024_8 (773224_8 if the processor traps to 224_8 on power-up).

The function performed by the power-up boot enable switch (S1-2) can be duplicated by an external switch using Faston tabs TP3 and TP4. A closed switch connected to TP3 and TP4 is equivalent to S1-2 being ON. When MOS memory is present with battery backup, a battery status signal is generated by the power supply. This signal should be attached to the power-up boot enable input (TP4) on the M9312. If this status signal goes low, it indicates that the contents of the MOS memory are no longer valid. The M9312, sensing the status of the memory, forces a boot on power-up allowing new data to be written into memory. When TP4 is used, switch S1-2 should be off.

If the battery status input is high (logic 1) the M9312 will not automatically boot on power-up, and the processor will obtain its new PC from location 24_8 , and its new PSW from location 26_8 .

1.5.2 Boot Selection

For power-up boot or external boot, the boot routine is selected by nine switches (S1-1 and S1-3 through S1-10) provided on the M9312. Appendix C shows switch configurations necessary for various boot routines.

1.5.3 External Boot Switch

A device can be externally booted by using an external boot switch connected to Faston tabs TP1 and TP2. When TP1 and TP2 are connected, BUS ACLO L will be asserted, causing the processor to perform a power-down. Upon releasing the switch, BUS ACLO L will be unasserted, initiating a power-up sequence in the CPU and M9312 address assertion (773000_8).

CHAPTER 2 HARDWARE DESCRIPTION

2.1 GENERAL

The M9312 Bootstrap/Terminator Module, through the use of interchangeable socketed ROMs, can be used on all PDP-11 processors. The description that follows will hold true for most applications. Various portions of the circuitry will be analyzed separately for clarity. M9312 circuit schematics (D-CS-M9312-0-1) will be referenced throughout the description.

2.2 ROM MEMORY

The five ROMs used for the console emulator routine, diagnostics and bootstrap programs in the M9312 are socketed to allow reconfiguration with a minimum of effort. Only half of each ROM is used by Unibus systems, the other half is reserved for use by other systems. The module has 512 words of read only memory. The lower 256 words (addresses 765000₈ through 765776₈) are used for the storage of ASCII console and diagnostic routines. The diagnostics (discussed further in Chapter 6) are rudimentary CPU and memory diagnostics. The upper 256 words (addresses 773000₈ through 773776₈) are used for storage of Bootstrap programs. These locations are divided further into four 64-word segments. If necessary more than one segment may be used for a boot program. Figure 2-1 illustrates the segregation of the ROMs.

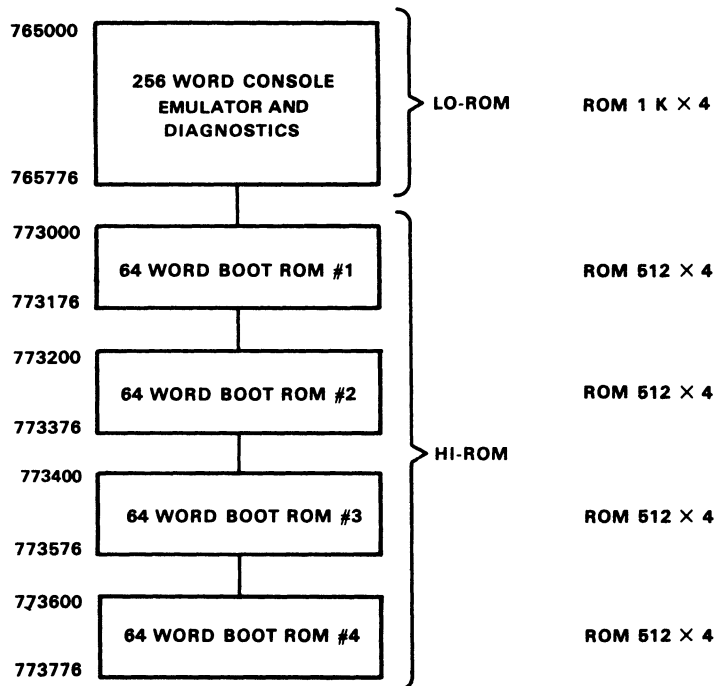

MA-0902

Figure 2-1 ROM Segregation

2.2.1 ROM Specifications

All PROM/ROM memories used on the M9312 must meet the requirements of Digital Equipment Corporation purchase specification 23-000A9-01 for the 512 × 4 (boot) ROMS and 23-000F1-01 for the 1K × 4 (CPU) ROM.

2.2.2 ROM Format

The following 64-word ROM format is required when writing a device boot which requires only one boot ROM in conjunction with the M9312 Bootstrap/Terminator Module.

1. The boot program must begin with a ROM header block.
2. Word address 24₈ of the ROM must remain reserved and be set to 173000₈.
3. Word address 26₈ of the ROM must remain reserved and be set to 340₈.
4. The last word of the ROM must be a CRC-16 word for the previous 63 words.

The following ROM format is required for device boots that need more than one ROM.

1. The first ROM follows the previously stated format.
2. The first word on each continued ROM must contain 177776₈.
3. The last word of each continued ROM must contain a CRC-16 word for the previous 63 words.
4. Any continued ROM that would occupy word address 773224₈ must reserve this location and put 173000₈ in it.
5. Any continued ROM that would occupy word address 773226₈ must reserve this location and put 340₈ in it.

2.2.2.1 ROM Header – As previously stated the beginning of a boot program must contain a header section. This header section is described below:

First word	Contains the ASCII identifier which consists of two characters with a zero-parity bit that will be used by the console emulator to identify a device for booting.
Second word	Contains the offset from this point to the next ROM header. If there is only one ROM header, this must point to the invisible first word of the next ROM.
Third word	Power-up entry point for unit zero, no diagnostics.
Fourth word	Power-up entry point for unit zero, diagnostic enabled.
Fifth word	Contains 000000, indicating unit 0 for instruction in previous word.
Sixth word	Entry point to ROM boot from the console emulator, R(0) must contain the unit number right justified. Enter here with C bit set if diagnostics are not desired. If diagnostics are desired, the C bit should not be set.

Seventh word Address of the control/status register of the device to be booted.

Eighth word Entry point when unit number of device to be booted is other than 0. This word moves R(7) to R(4).

Ninth word Contains a branch instruction (BCC) to a link to the secondary diagnostic code.

2.2.3 ROM Data

2.2.3.1 ROM Data Transfer – Data stored in the ROMs is addressed four bits at a time. These four bits are shifted through the output latches (E11 and E12) until a 16-bit word is ready to be transferred to the Unibus. A block diagram of this procedure is shown in Figure 2-2. Table 2-1 shows the relationship between the data word bit number and the output of the ROMs. It should be noted that bits 10, 11, and 12 must be stored inverted.

2.2.3.2 ROM Data Organization – As previously stated all ROM memory on the M9312 is four bits wide. Table 2-1 shows how 16-bit words are organized in the ROMs.

Table 2-1 ROM Data Organization

ROM Output	Data	Word	Bit	Number
4	15	$\overline{11}$	7	3
3	14	$\overline{10}$	6	2
2	$\overline{13}$	9	5	1
1	$\overline{12}$	0	4	8
ROM Address	3 ₈	2 ₈	1 ₈	0 ₈
Data Word 1				
ROM Address	377 ₈	376 ₈	375 ₈	374 ₈
Data Word 64				

NOTE

Data word bits 10, 11, and 12 are stored inverted.

2.2.4 Requirements for New ROMs and Uses of the M9312

M9312 specification A-SP-M9312-0-8 must be referred to for new uses of the M9312 and for creation of new ROMs.

2.3 POWER-UP SEQUENCE

Typically all PDP-11 computers perform a power-up sequence each time power is applied to their CPU module(s). This sequence is as follows.

1. +5 Vdc comes true.
2. BUS DCLO L is unasserted by power supply.
3. BUS ACLO L is unasserted by power supply.
4. BUS INIT asserts for approximately 100 ms.

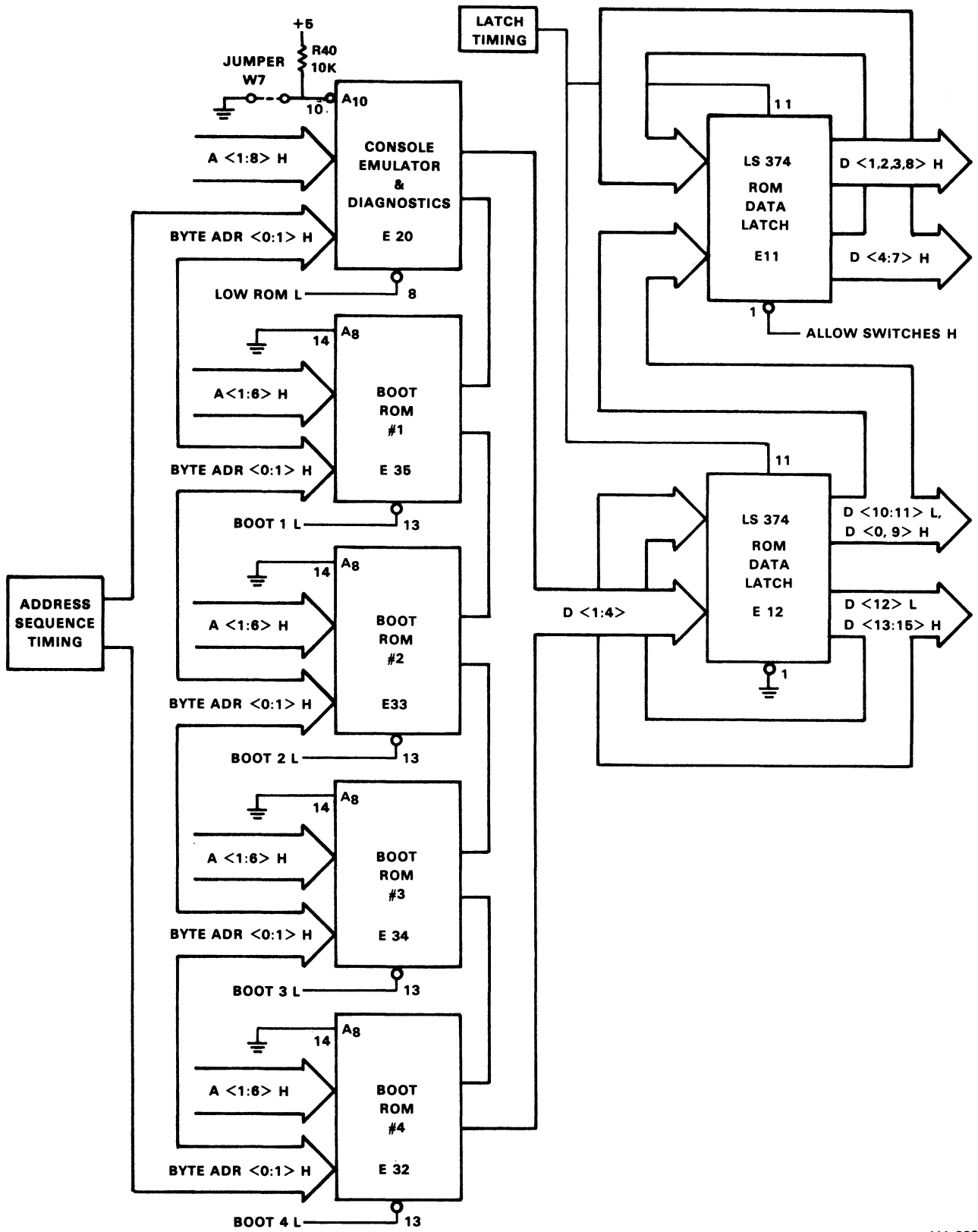

MA-0903

Figure 2-2 ROM Data Transfer

5. Processor accesses memory location 24_8 for new PC.
6. Processor accesses memory location 26_8 for new PSW.
7. Processor begins running program at new PC contents.

With an M9312 Bootstrap/Terminator Module in the PDP-11 computer system, on power-up the user can optionally force the processor to read its new PC from a ROM memory location and the Offset Switch Bank on the M9312 (Unibus location 773024_8). A switch (S1-2) on the M9312 or an external switch on Faston tabs TP3 and TP4 can enable or disable this feature. The new PSW will be read from a location (Unibus location 773026_8) in the M9312 memory. This new PC and PSW will then direct the processor to a program (typically a bootstrap) in the M9312 ROM memory (Unibus memory locations 773000_8 through 773776_8 , and 765000_8 through 765776_8).

If the boot enable switch (S1-2) is off, an external switch or logic level can be used to make the processor execute a boot program on power-up. Programs in the M9312 can also be initiated by program jumps to their starting addresses or through the START switch feature of a programmer's switch console if one is available in the system.

2.4 POWER-UP BOOTING LOGIC

The status of every Unibus PDP-11 power supply is described by the two Unibus control lines BUS ACLO L and BUS DCLO L. The condition of these two lines in relation to the +5 V output of the power supply is defined by Unibus specifications as summarized in Figure 2-3.

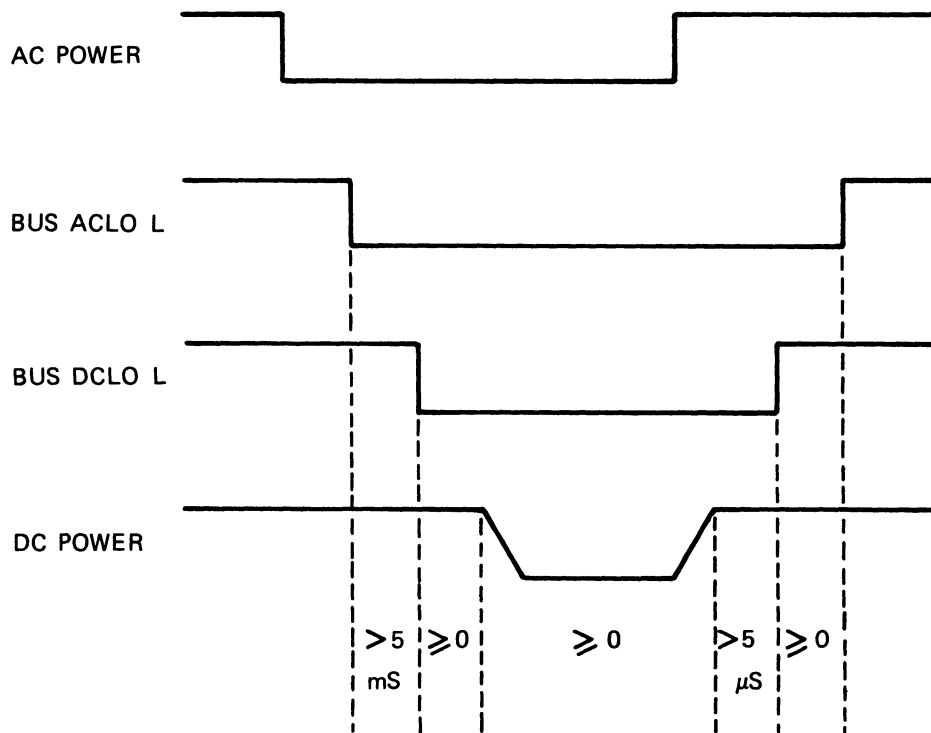

MA-0901

Figure 2-3 Power-Down/Power-Up Sequence

2.4.1 Power-Up and Power-Down

On the M9312, power-up sequences are detected by the circuitry shown in Figure 2-4. When +5 V first becomes true, both BUS ACLO L and BUS DCLO L are asserted low. Assuming the power-up boot-enable switch is closed a high to low transition out of E8 (pin 3) (POWER-UP BOOT L) triggers the one shot E7 (pin 5) which asserts Unibus address lines BUS A 09 L, BUS A 10 L, and BUS A 12 L through BUS A 17 L for up to 300 ms. The logic shown in Figure 2-5 generates these Unibus addresses.

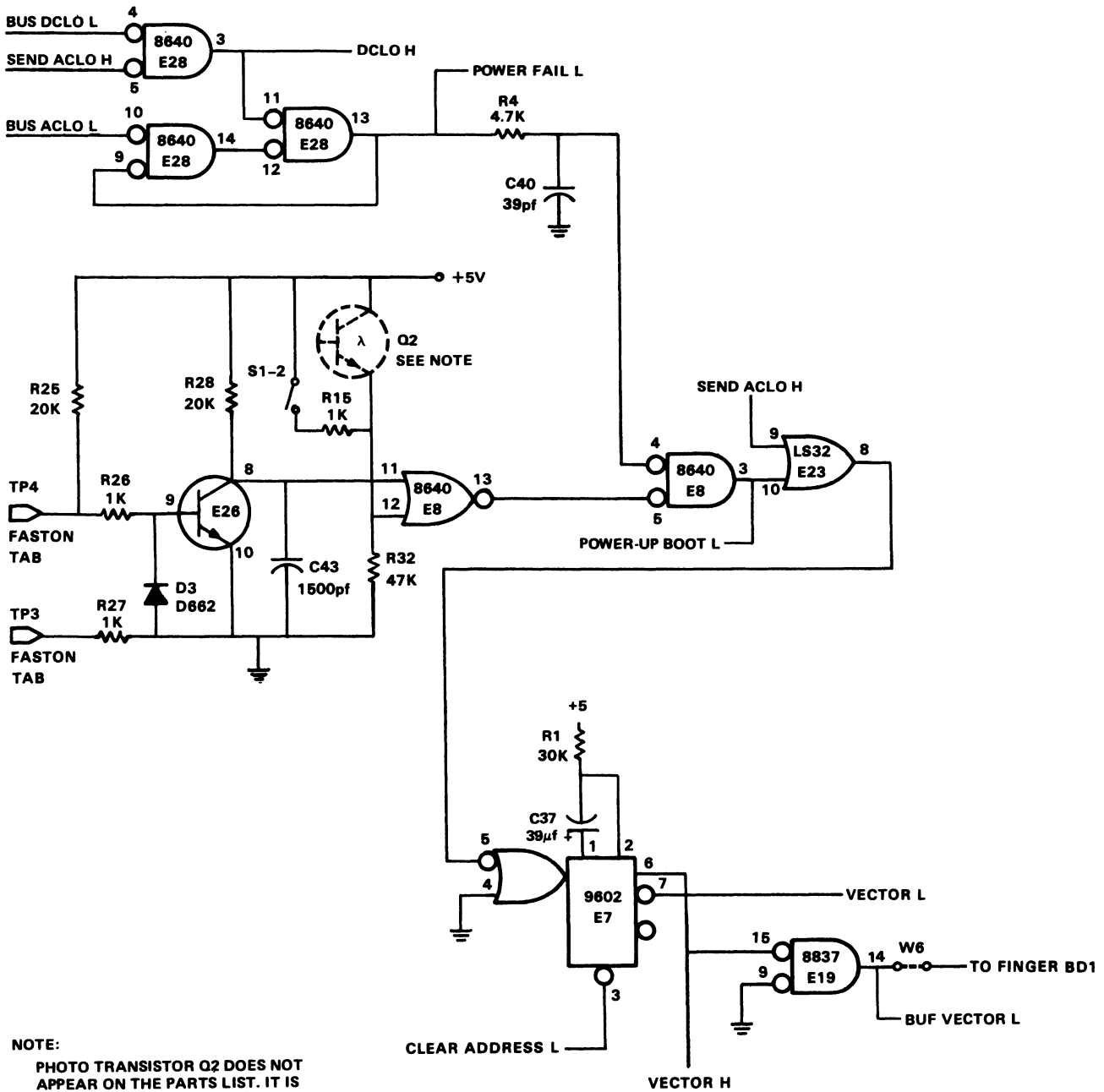

MA-0904

Figure 2-4 Power-Up Boot Logic

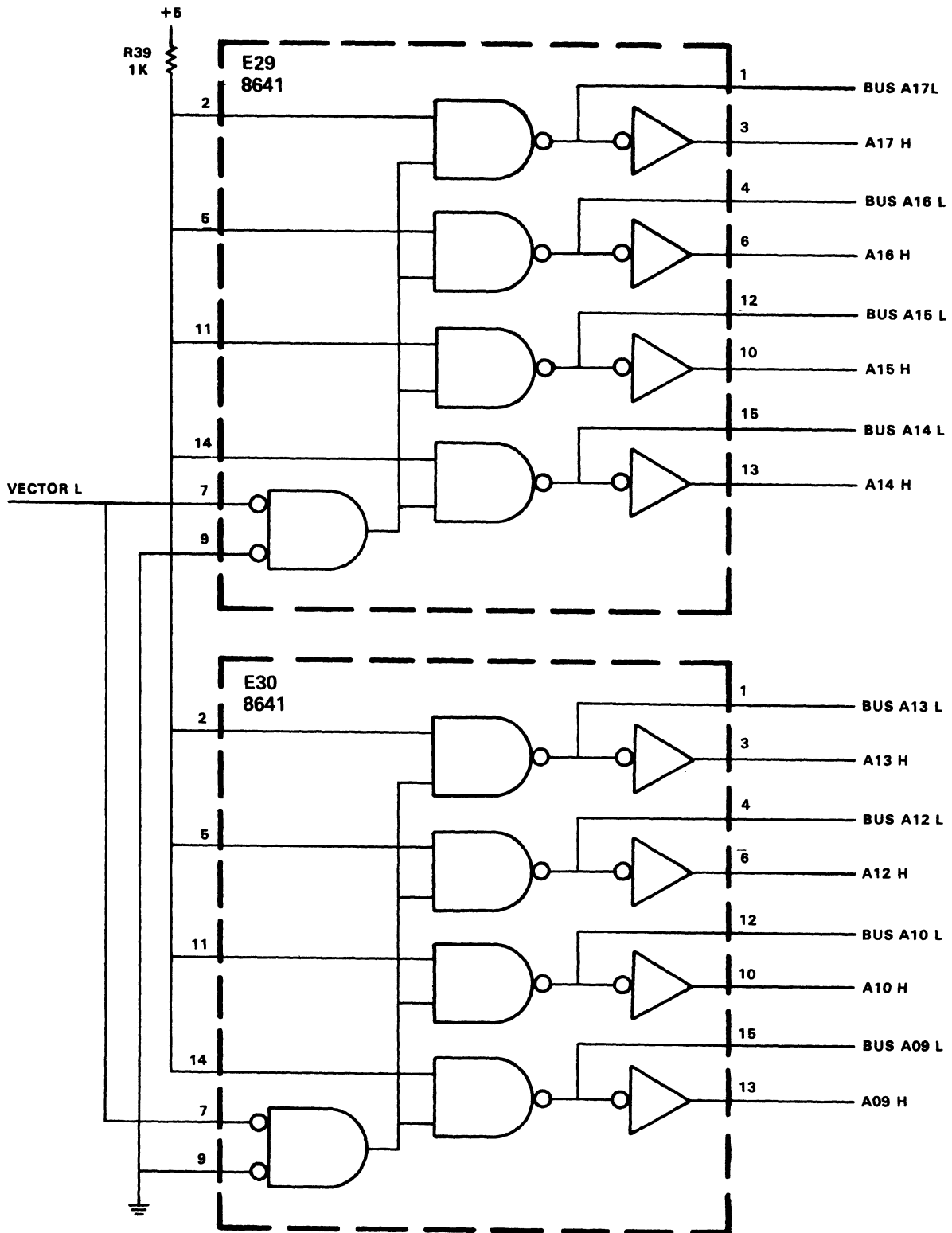

MA-0905

Figure 2-5 Address Generation Logic

2.4.2 Processor Reads New Program Counter

During the 300 ms maximum assertion time, the central processor will be performing its power up sequence. When the processor attempts to read a new program counter (PC) address from memory location 24₈, the address bits enabled by the one shot E7 are logically ORed to generate the address 773024₈. This location is an address in the M9312 ROM space and the address of the Offset Switch Bank, which contains the starting address of a specific routine.

2.4.3 Processor Reads New Status Word

Having obtained a new PC from location 773024₈, the processor then attempts to read a new processor status word (PSW) from memory location 26₈. The address bits enabled by the one shot E7 (pin 7) are logically ORed to generate the address 773026₈ which is also in the M9312 ROM address space. Once this transfer is completed, the processor unasserts MSYN L and 150 ns (minimum) later the M9312 clears its asserted addresses. The M9312 unasserts SSYN L 800 ns after the unassertion of MSYN L freeing the Unibus. The 300 ms one-shot (E7 pin 7) guarantees enough time for any PDP-11 processor to complete the two memory transfers described, before releasing the address lines.

2.4.4 Power-Up Boot Enable Switch

The power-up boot enable switch (S1-2) can be used to disable the logic shown in Figure 2-4. With this switch off (TP3 and TP4 open), the output of E8 (pin 3) will always be low, preventing one-shot E7 (pin 7) from ever being set on power restarts. Faston tabs TP3 and TP4 are provided to allow S1-2 to be remotely duplicated or accept a battery status input. Note that when Faston tab TP4 is used, S1-2 must be left in the off position.

2.5 EXTERNAL BOOT CIRCUIT

The processor can be activated externally by connecting Faston tabs TP1 and TP2 or by applying a logic '0' to TP1 (Figure 2-6). This sets flip-flop E6 (pin 15), which then generates an asserted BUS ACLO L signal on the Unibus. Upon seeing this Unibus signal, the processor will begin a power-down routine, anticipating a real power failure. After completing this routine, the processor will then wait for the unassertion of BUS ACLO L, at which time it will perform a power-up sequence through location 24₈ and 26₈.

Upon release of the external boot switch or return to logic '1' at TP1, the set input to flip-flop E6 (pin 2) is unasserted and one-shot E7 on the M9312 is triggered, causing a 100 ms timeout. At the end of the timeout, BUS ACLO L is unasserted and the 300 ms one shot E7 (pin 10) is triggered. The processor is then forced to read its new PC and PSW from locations 773024₈ and 773026₈ respectively. The external boot timing is shown in Figure 2-7.

2.6 POWER-UP TRANSFER DETECTION LOGIC

Any time one-shot E7 (Pin 6) is set, bus address lines [BUS A (9, 10, 12:17) L] are asserted. The circuit shown in Figure 2-8 clears the address lines until BUS DCLO L becomes unasserted. When a boot occurs and the new PC and PSW have been transferred, the circuitry has received two MSYN signals and MSYN COUNT L goes low. At this time the bus address lines are unasserted. If the above transfers do not occur within 300 ms, the address lines are unasserted.

2.7 POWER-UP CLEAR

The circuit shown in Figure 2-9 holds the external boot circuit clear for approximately 8 ms after the dc supply voltage exceeds the threshold voltage of 3.0 to 4.5 V. This is to ensure that the external boot circuit does not cause a boot on power-up. The circuit uses the M9312's dc supply voltage to determine if a real power failure has occurred, because an assertion BUS ACLO L and BUS DCLO L may occur without a real power failure.

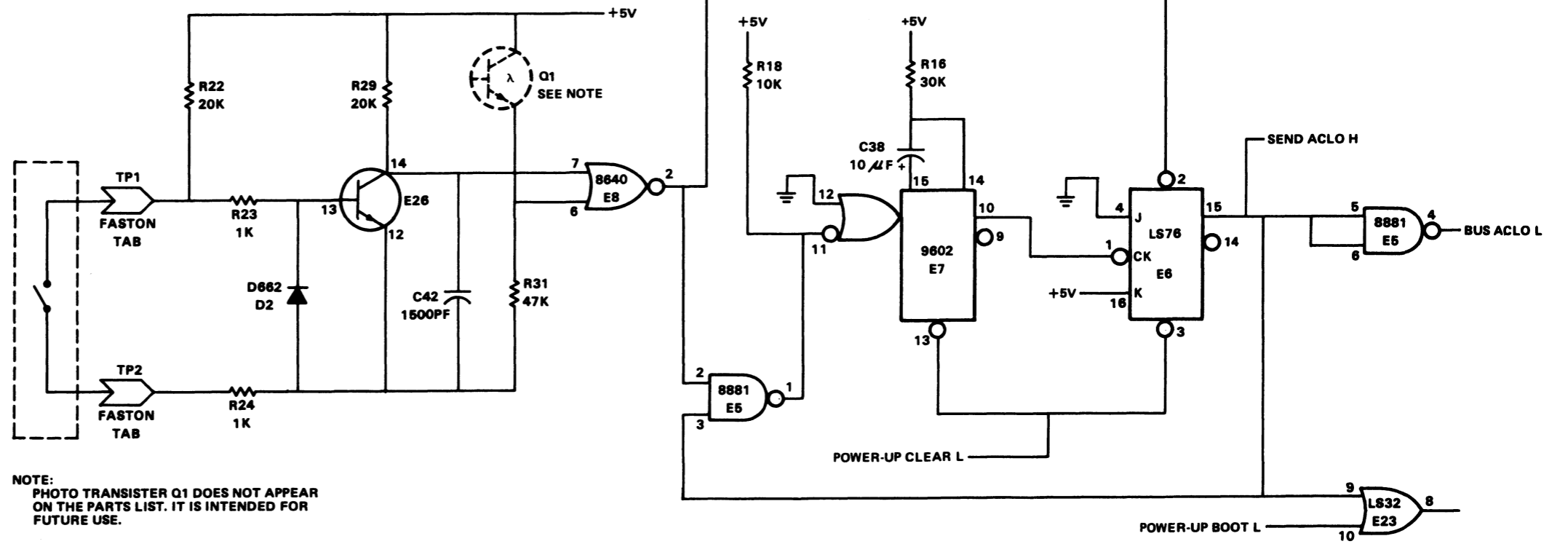

NOTE:
PHOTO TRANSISTOR Q1 DOES NOT APPEAR
ON THE PARTS LIST. IT IS INTENDED FOR
FUTURE USE.

MA-0906

Figure 2-6 External Boot Logic

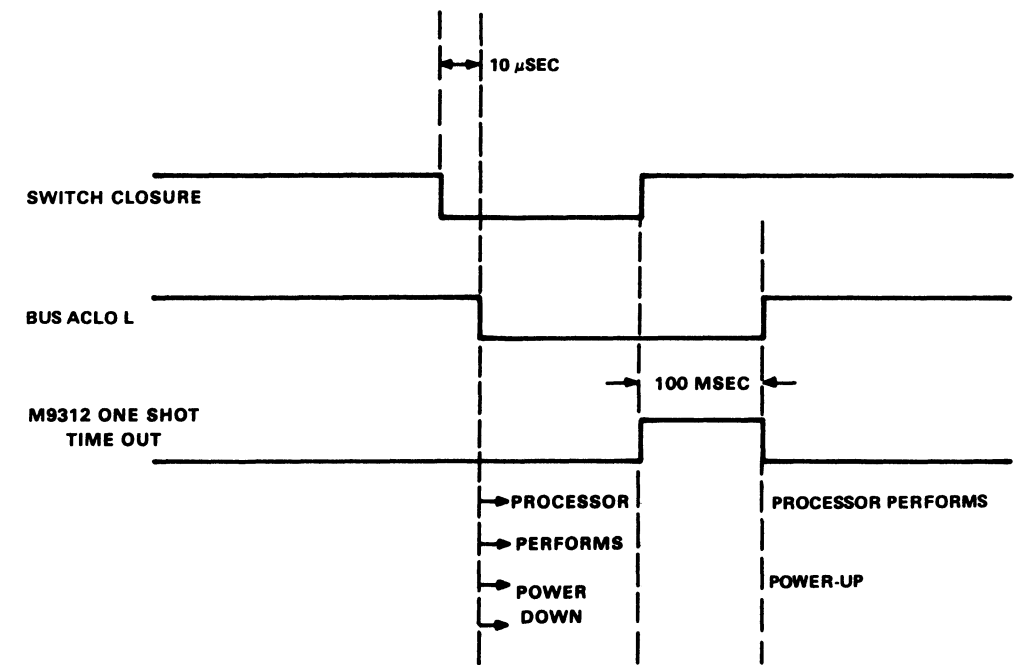

MA-0907

Figure 2-7 External Boot Timing

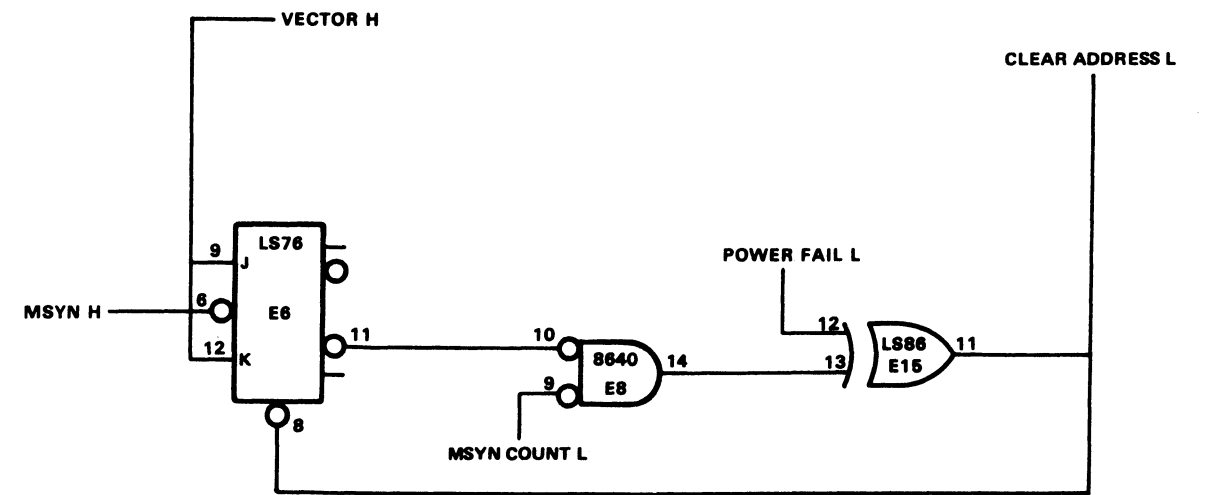

MA-0908

Figure 2-8 Power-Up Transfer Detection Logic

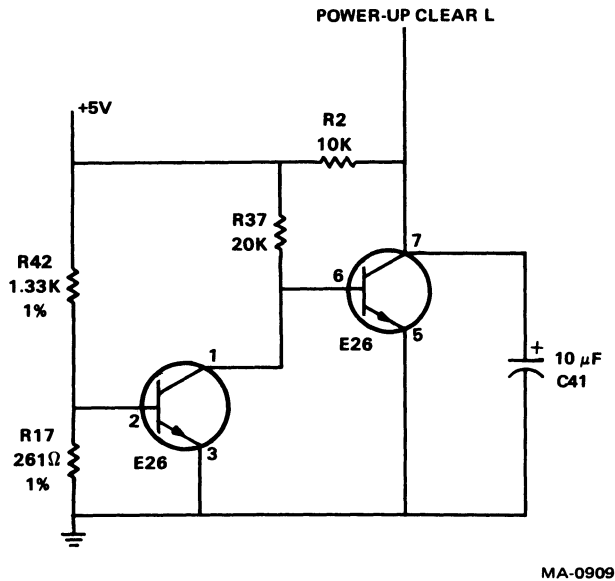

Figure 2-9 Power-Up Clear Circuitry

2.8 ADDRESS DETECTION LOGIC

2.8.1 M9312 Address Space

Address detection logic on the M9312 detects Unibus addresses within the address space 773000₈ through 773776₈ and 765000₈ through 765776₈. It also recognizes the specific address 773024₈. Some processors, such as the PDP-11/60, trap to locations 224₈ and 226₈ on power-up for their new PC and PSW. The M9312 also recognizes the specific address 773224₈. Figure 2-10 illustrates the M9312's address detection logic.

2.8.2 Memory Access Constraints

Upon receiving a recognized Unibus address and BUS MSYN, the M9312 ROM data output is transferred to the Unibus data lines (BUS D00 L through BUS D15 L) and BUS SSYN L is enabled. Conditions which must be met before transferring the ROM data and returning BUS SSYN are as follows:

1. Detection of the Unibus address 773XXX₈ or 765XXX₈ where XXX₈ is any even address. Installing W-8 disables detection of address 765XXX₈.
2. Transfer being performed is a DATI operation where BUS C1 L is not asserted.
3. An asserted BUS MSYN L control signal has been obtained.

2.8.3 LO ROM ENA H Jumper

LO ROM ENA H jumper W-8 allows the user to disable the M9312 detection of Unibus addresses 765000₈ through 765776₈. Disabling the detection of these addresses (W-8 in) becomes essential when that memory space is being used by other peripheral device(s) in the system. Users should note that when detection of these addresses is disabled the console emulator and diagnostic routines in the M9312 are eliminated (not addressable).

ALLOW SWITCHES ROM

ADDRESSES A <8:1> H	HIGH ROM H	ENABLE ROM L	JUMPERS W-9 AND W-10	JUMPERS W-11 AND W-12	ALLOW SWITCHES L	ALLOW SWITCHES H
XXX	X	H	X	X	H	H
XXX	L	L	IN	OUT	H	L
XXX	L	L	OUT	IN	H	L
024	H	L	IN	OUT	L	H
DEFAULT	X	L	IN	OUT	H	L
224	H	L	OUT	IN	L	H
DEFAULT	X	L	OUT	IN	H	L

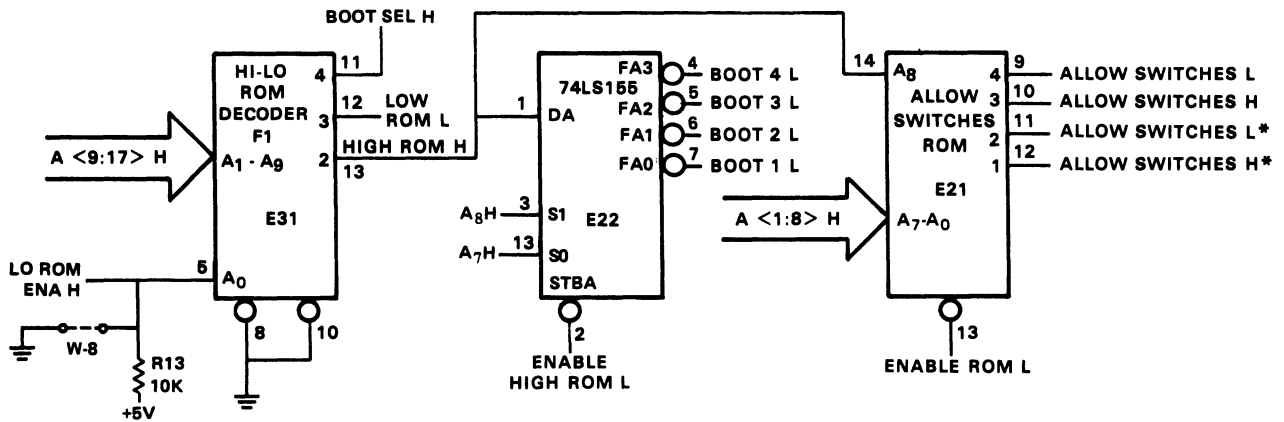

HI-LO ROM DECODER

ADDRESSES A <17:9>	LO ROM ENA H	BOOT SEL H	LOW ROM L	HIGH ROM H
7 6 5 X X X	H	H	L	L
7 6 5 X X X	L	L	H	L
7 7 3 X X X	X	H	H	H
DEFAULT	X	L	H	L

74LS155

A ₈	A ₇	ENABLE HIGH ROM L	HIGH ROM H	BOOT 1 L	BOOT 2 L	BOOT 3 L	BOOT 4 L
L	L	L	H	L	H	H	H
L	H	L	H	H	L	H	H
H	L	L	H	H	H	L	H
H	H	L	H	H	H	H	L
X	X	X	L	H	H	H	H
X	X	H	X	H	H	H	H

* THESE OUTPUTS ARE USED WHEN MODULE IS BEING USED WITH PROCESSORS THAT OBTAIN THEIR NEW PC AT LOCATION 224_(B) AND PSW AT 226_(B).

MA-0910

Figure 2-10 Address Detection Logic

2.9 ADDRESS OFFSET SWITCH BANK

As previously mentioned, on a power-up boot or an external boot, the M9312 forces the processor to obtain its new PC from location 773024₈ instead of location 24₈. When the M9312 address detection logic decodes address 773024₈, it enables (via ALLOW SWITCHES L) the Address Offset Switch Bank (Figure 2-11). The contents of the switches S1-1 and S1-3 through S1-10 combined with the contents of the specified address in M9312 ROM memory produce a new PC for the CPU. The new PC will point to HI or LO ROM memory depending upon the position of the switch S1-1. With S1-1 OFF the new PC will point the processor to a starting address of a bootstrap program (addresses 773000₈ through 773776₈) in M9312 ROM memory. When S1-1 is ON, the new PC will point the processor to a starting address of a program in the M9312 console emulator and diagnostic ROM (addresses 765000₈ through 765776₈). Several programs can be included in M9312 memory with any one being user selectable through the Address Offset Switch Bank. Appendix C shows the relationship between the switches and the devices to be booted.

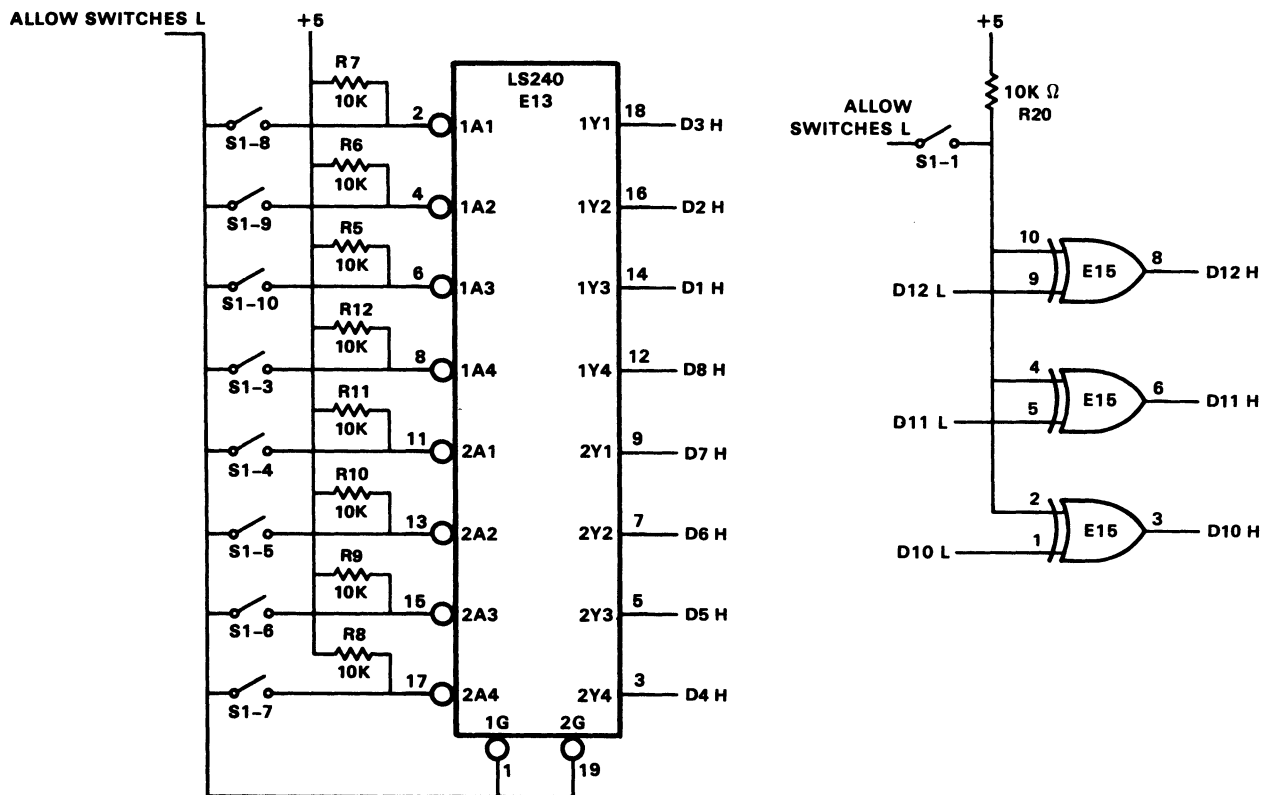

OFFSET SWITCHES AND CORRESPONDING BUS ADDRESS BITS

S1 SWITCHES	1	3	4	5	6	7	8	9	10	*		
CORRESPONDING BUS ADDRESS BITS	12	11	10	8	7	6	5	4	3	2	1	0
BINARY VALUE OF SWITCHES		X	X	X	X	X	X	X	X	X	X	0
OCTAL VALUE OF SWITCHES		Y			Y			Y				

*NO SWITCH IS PROVIDED FOR SETTING BIT 0, THEREFORE ONLY EVEN ADDRESS (FOR THE PC) MAY BE SET.

MA - 0911

Figure 2-11 Address Offset Switch Bank

2.10 M9312 TERMINATOR

The terminator section of the M9312 consists of four resistor pack circuits, each containing the required pull-up (178 ohms) and pull-down (383 ohms) resistors for proper Unibus termination. Since PDP-11/04, 11/34 and 11/34A processors contain Bus Grant pull-up resistors, and other processors do not, the M9312 allows a choice of whether or not to pull up the BUS grant lines. When jumpers W-1 through W-5 are in, these lines are pulled up; when these jumpers are out, the grant lines are not pulled up.

CHAPTER 3 CONSOLE EMULATOR

3.1 GENERAL

The console emulator routine is available when a ROM which contains the routine is used on the M9312. This ROM is placed in the console emulator and diagnostic ROM socket shown in Figure 1-1.

3.2 USING THE CONSOLE EMULATOR

The system will execute a console emulator power-up routine when power is supplied to the system, the boot switch is pressed, or the correct address from Table 3-1 is loaded and started, provided jumper W-8 is out, W-7 is in, and the Address Offset Switch Bank is set according to Table 3-1. If diagnostics are selected, secondary diagnostics (tests 6 and 7) will run after the console emulator routine, just before a boot. Primary diagnostic tests 1 through 4 are always executed before the console emulator routine. Completion of the primary diagnostic tests will be followed by the register display routine. The contents of R0, R4, R6, and R5 will be printed out on the terminal. An @ sign will be printed at the beginning of the next line of the terminal, indicating that the console emulator routine is waiting for input from the operator.

Table 3-1 Console Emulator Switch Requirements

	Octal Address†	Address Offset Switch Bank S1									
		1	2*	3	4	5	6	7	8	9	10
Console Emulator with Diagnostics	165020	ON	-	OFF	OFF	OFF	OFF	ON	OFF	OFF	OFF
Console Emulator without Diagnostics	165144	ON	-	OFF	OFF	ON	ON	OFF	OFF	ON	OFF

*When switch S1-2 is ON, power-up boot is enabled; when S1-2 is OFF power-up boot is disabled.

†The octal address can be loaded and program started from a programmer's console or switch register, if a power-up start or external boot start from the M9312 is not used.

The following symbols will be used in this discussion.

<SB>: Space bar
 <CR>: Carriage return key
 X: Any octal number 0-7

The four console functions can be exercised by pressing keys, as follows:

Function	Keyboard Strokes
Load Address	L<SB> XXXXXX <CR>
Examine	E<SB>
Deposit	D<SB> XXXXXX <CR>

The first digit typed will be the most significant digit. The last digit typed will be the least significant digit. If an address or data word contains leading zeros, these zeros can be omitted when loading the address or depositing the data. An example using the load, examine, deposit, and start functions follows. Assume a user wishes to:

1. Load address 700
2. Examine location 700
3. Deposit 777 into location 700
4. Examine location 700
5. Start at location 700.

To accomplish this, the procedure below must be followed.

Operator Input	Terminal Display
1. Turns on power	XXXXXX XXXXXX XXXXXX XXXXXX
2. L<SB> 700<CR>	@L 700
3. E<SB>	@E 000700 XXXXXX
4. D<SB> 777<CR>	@D 777
5. E<SB>	@E 000700 000777
6. S<CR>	@S

NOTE

The console emulator routine will not work with odd addresses. Even addresses must always be used.

3.2.1 Successive Operations

3.2.1.1 Examine – Successive examine operations are permitted. The address is loaded for the first examine only. Successive examine operations cause the address to increment and will display consecutive addresses along with their contents. For example, to examine addresses 500–506, the following procedure may be used.

Operator Input	Terminal Display
L<SB>500<CR>	@L 500
E<SB>	@E 000500 XXXXXX
E<SB>	@E 000502 XXXXXX
E<SB>	@E 000504 XXXXXX
E<SB>	@E 000506 XXXXXX

3.2.1.2 Deposit – Successive deposit operations are permitted. The procedure is identical to that used with examine. For example, to deposit 60 into location 500, 2 into location 502, and 4 into location 504:

Operator Input	Terminal Display
L<SB>500<CR>	@L 500
D<SB>60<CR>	@D 60
D<SB>2<CR>	@D 2
D<SB>4<CR>	@D 4

3.2.1.3 Alternate Deposit-Examine Operations – This mode of operation will not auto-increment the address. The location addressed will contain the last data which was deposited. For example, to load address 500 and deposit 1000, 2000, and 5420 with examine operations after every deposit:

Operator Input	Terminal Display
L<SB>500<CR>	@L 500
D<SB>1000<CR>	@D 1000
E<SB>	@E 000500 001000
D<SB>2000<CR>	@D 2000
E<SB>	@E 000500 002000
D<SB>5420<CR>	@D 5420
E<SB>	@E 000500 005420

3.2.1.4 Alternate Examine-Deposit Operations – If an examine is the first instruction after a load sequence and is alternately followed by deposits and examines, the address will not be incremented, and the address will contain the last data which was deposited. The prior example applies to this operation, and with the exception of the order of examine and deposit, the end result is the same.

3.2.2 Limits of Operation

The M9312 console emulator can directly manipulate the lower 28K of memory and the 4K I/O page. See Chapter 5 for an explanation of techniques required to access addresses above the lower 28K.

3.3 BOOTSTRAPS STARTED FROM THE CONSOLE EMULATOR

Once the @ symbol has been displayed in response to system power-up, or pressing the boot switch, the system is ready to boot a device the operator selects. The procedure is as follows.

1. Load paper tape, magtape, disk, etc., into the peripheral to be booted, if required.
2. Verify that the peripheral indicators signify that the peripheral is ready (if applicable).
3. Find the boot command code in Table 3-2 that corresponds to the peripheral to be booted. Type the code obtained from the table. (The @ sign will be returned at this point if the correct boot ROM has not been installed, or if a non-existent code is typed in. If the register display is printed first, the emulator is indicating that at least one boot ROM socket is available for boot ROM installation.)
4. If there is more than one unit of a given peripheral, type the unit number to be booted (0-7). If no number is typed, the default number will be 0.
5. Type <CR>, which initiates the boot.

Table 3-2 Boot Command Codes

Interface	Device	Description	Command Code
RL11	RL01	Disk Memory	DL
RX11	RX01	Floppy disk system	DX
RK11C,D	RK03,05/05J	DECpack disk	DK
TC11	TU55/56	Dual DECTape	DT
RX211	RX02	Double density floppy disk system	DY
RK611	RK06/07	Disk drive	DM
TM11/A11/B11	TS03,TU10	Magnetic tape (9 track, 800 bits/in, NRZ)	MT
RH11/RH70	TU16,TM02	Magnetic tape	MM
TA11	TU60	Dual magnetic tape	CT
PC11		High speed reader	PR
DL11-A		Low speed reader	TT
RP11	RP02/03	Moving head disk	DP
RH11/RH70	RP04/05/06	Moving head disk	DB
	RM02/03		
RH11/RH70	RS03/04	Fixed head disk	DS

Before booting a device always remember:

1. The medium (paper tape, disk, magtape, cassette, etc.) must be placed in the peripheral to be booted prior to booting.
2. The machine will not be under the control of the console emulator routine after booting.
3. The program which is booted in must:
 - a. Be self-starting or
 - b. Allow the user to load another program by using the CONT function or
 - c. Be startable from the console emulator or switch register after having been booted in.

3.3.1 Booting the High-Speed Reader Using the Console Emulator

To load the CPU diagnostic for a PDP-11/34 computer system with a high-speed reader, perform the following procedure.

1. Place the HALT/CONT switch in the CONT position.
2. Obtain a @ symbol by either turning on system power or actuating the boot switch. (R0, R4, SP, and old PC will be printed prior to the @ symbol.)
3. Place the absolute loader paper tape (coded leader section) in the high speed reader.
4. Type PR<CR>.

The absolute loader tape will be loaded and the machine will halt.

5. Remove the absolute loader and place the leader of the program, in this case a CPU diagnostic, in the reader.
6. Move the HALT/CONT switch to HALT and then return it to CONT. The diagnostic will be loaded and the machine will halt (normal for this program; non-diagnostic programs may or may not be self-starting.)
7. If program is not self-starting, activate the BOOT/INIT switch. This will restart the console emulator routine.
8. Using the console emulator, deposit desired functions into the software switch register (a memory address) location. (See the diagnostic for the software switch register's actual location and significance.)
9. Using the console emulator, load the starting address, and start the program as described earlier in this section.

3.3.2 Booting a Disk Using the Console Emulator

To boot the system's RK05 disk, which contains the CPU diagnostics that you want to run, perform the following procedure:

1. Verify that the HALT/CONT switch is in the CONT position and the write lock switch on the RK11 peripheral is in the ON position.
2. Turn on system power or press the console boot switch. The system terminal displays R0, R4, SP and old PC in octal numbers followed by a @ symbol on the next line.
3. Place the disk pack in drive 0.
4. When the RK05 load light appears, the system is ready to be booted.
5. Type DK<CR>. This causes the loading of the bootstrap routine into memory and the execution of that routine.
6. The program should identify itself and initiate a dialogue (which will not be discussed here).

3.4 RECOVERING FROM ERRORS IN THE CONSOLE EMULATOR ROUTINE

Table 3-3 describes the effects of entering information incorrectly to the console emulator routine. The following symbols are used in the table.

(9) Represents a non-octal number (8 or 9)

(Y) Represents:

1. All keys (other than numerics) which are unknown.
2. Keys which are known but do not constitute a valid code in the context which they are entered.

Refer to previous sections for a discussion of the correct method operating the console emulator routine.

Table 3-3 Deposit Errors: Useful Examples

Error	Result	Remedy	Operator	Terminal
L was followed by a key other than (SB).	Terminal display will immediately return an @ to signify an unknown code. No address is loaded.	Try again	L(Y)	@L @
An illegal (non octal) number (8 or 9) is typed after the correct load entrance, within an otherwise valid number.	Upon receipt of the illegal number, the Console Emulator will ignore the entire address and return an @.	Try again	L<SB> XXX9	@L XXX9 @
An alphabetic key is typed after the correct load entrance within an otherwise valid number.	Same as illegal number.	Try again	L<SB> XXX Y	@L XXXY @
The most significant octal number in a six bit address is greater than one.	An address will be loaded. However, the state of the most significant address bit will be determined by bit 15 only: 2 = 0 3 = 1 4 = 0 5 = 1 6 = 0 7 = 1	Try again if required	L<SB> 6XXXXX <CR>	@L 6XXXXX @ (address loaded 0XXXXX)
An unwanted but legal octal number is loaded.	Unwanted address will be loaded.	Try again		
An extra (seventh) octal number is typed.	The loaded number will be incorrect. The system will accept any size number but will only remember the last six characters typed in.	Try again	L<SB> 1XXXXX <CR>	@L 1XXXXX @ (Actually Loads XXXXXX)
A memory location higher than the highest memory location available in the machine is loaded.	No errors will result unless a deposit, examine, or start is attempted, causing Bus to hang up.	Try again	L<SB> 1XXXXX <CR>	L 1XXXXXX @
L, <SB> and number were entered correctly, <CR> was not entered.	Machine will wait indefinitely for <CR>. @ will not be returned	Type <CR>	L<SB> XXXXX <CR>	@L XXXXXX @

Table 3-3 Deposit Errors: Useful Examples (Cont)

Error	Result	Remedy	Operator	Terminal
<p>Examine or start is attempted to a memory location which is higher than the highest available memory location in the machine (I/O page can be examined) or to an odd memory location.</p>	<p>The system will hang up.</p>	<p>Actuate the boot switch</p>	<p>E<SB> or S<CR></p>	<p>@E or @S (stops responding)</p>
<p>Examine is performed without loading an address prior to first examine.</p>	<p>An examine operation of an unknown address will be performed. It is possible that the machine may attempt to examine an address which does not exist. If this happens the system will hang-up.</p>	<p>Try again or boot if system hangs up.</p>	<p>E<SB></p>	
<p>Start is performed without loading an address prior to starting.</p>	<p>Start at an unknown location will occur.</p>	<p>Depress the boot switch, load correct address and then start.</p>		
<p>D was followed by a key other than a space or a valid second character of a boot command code.</p>	<p>Terminal display will immediately return a @ to signify an unknown code. If the register display is printed before the @ sign, the emulator is indicating that at least one socket is still available for a boot ROM.</p>	<p>Try again</p>	<p>D(Y)</p>	<p>@D(Y) @</p>
<p>Deposit is attempted to a memory location which is higher than the highest available memory location in the machine (with the exception of the I/O page).</p>	<p>The system will hang up when <CR> is executed.</p>	<p>Depress the boot switch and start over again.</p>		

Table 3-3 Deposit Errors: Useful Examples (Cont)

Error	Result	Remedy	Operator	Terminal
Deposit is performed without loading an address or knowing what address has been previously loaded.	<p>a. Data will be written over and lost</p> <p>b. Machine might hang up.</p>	<p>a. Immediately following the error, perform an examine to determine the location which was accessed. Restore original contents if known.</p> <p>b. Actuate the boot switch.</p>		
Deposit into an odd address is attempted.	The system will hang up when <CR> is executed.	Actuate the boot switch.		

Escape Route

If an entry has not been completed and the user realizes that an incorrect or unwanted character has been entered, press the rubout or delete key. This action will void the entire entry and allow the user to try again.

Machine “Hang-Up”

Machine has “hung-up” (halted or gone into program loop) if the terminal does not respond to any keyboard entry.

CHAPTER 4 BOOTSTRAPPING

The routines to bootstrap a device typically read in the first sector, block, or 512 words from the device into location 0 through 512 of memory. The exception to this rule is the paper tape boot. The paper tape boot is unique in that it can do no error checking and the secondary bootstrap (the absolute loader, for example) is read into the upper part of memory. The actual locations loaded by the paper tape boot are partially determined by the secondary bootstrap itself and by the size routine which determines the highest available memory address within the first 28K. The flexible disk (or floppy) reads sector 1 on track 1 into consecutive locations starting at 0. The magnetic tape boots read the second block into consecutive locations starting with 0. If no errors are detected in the device, the bootstraps normally transfer control to location 0 in order to execute the secondary bootstrap just loaded. The only exception to this starting address concerns the paper tape boots. They transfer control to location XXX374, where XXX is determined initially by the size routine to be at the top of memory. This is where the absolute loader has just been loaded.

If a device error is detected, a reset will be executed and the bootstrap will try again. The bootstrap will be retried indefinitely until it succeeds without error unless the user (operator) intervenes. The advantage of retrying the boot is that if a particular device being booted is not on-line or not loaded, perhaps because of a power failure, the boot will give the device a chance to power-up (essential for disks).

A magnetic tape transport, however, will not automatically reload itself after a power failure and restart. This situation requires user intervention. The user must reload the magtape and bring it back on-line, at which time the magtape bootstrap, which will have been continually attempting to boot the tape, will succeed.

CHAPTER 5 EXTENDED ADDRESSING

5.1 GENERAL

This chapter applies to use of the M9312 in PDP-11 systems which have no console. When the memory of a PDP-11 system is extended beyond 28K, the processor is able to access upper memory through the memory management system. However, the console emulator normally allows the user to access only the lower 28K of memory. This chapter provides an explanation of the method by which the user can gain access to upper memory in order to read or modify the contents of any location. The reader should be familiar with the concepts of memory management in the KD11-E processor.

5.2 VIRTUAL AND PHYSICAL ADDRESSES

Addresses generated in the processor are called virtual addresses, and will be 16 bits in length. Physical addresses refer to actual locations in memory. They are asserted on the Unibus and may be up to 18 bits in length (for 128K memories).

5.3 ADDRESS MAPPING WITHOUT MEMORY MANAGEMENT

With memory management disabled (as is the case following depression of the boot switch), a simple hardware mapping scheme converts virtual addresses to physical addresses. Virtual addresses in the 0 to 28K minus 2 range are mapped directly into physical addresses in the range from 0 to 28K minus 2. Virtual addresses on the I/O page, in the range from 28K to 32K minus 2 (160000₈ to 177776₈), are mapped into physical addresses in the range from 124K to 128K minus 2, or the last 4K of memory.

5.4 ADDRESS MAPPING WITH MEMORY MANAGEMENT

With memory management enabled, a different mapping scheme is used. In this scheme, a relocation constant is added to the virtual address to create a physical or "relocated" address.

Virtual address space consists of eight 4K banks where each bank can be relocated by the relocation constant associated with that bank. The procedure specified in this section allows the user to:

1. Create a virtual address to type into the load address command.
2. Determine the relocation constant required to relocate the calculated virtual address into the desired physical address.
3. Enable or disable the memory management hardware.

5.5 CREATION OF A VIRTUAL ADDRESS

The easiest way to create a virtual address is to divide the 18-bit physical address into two separate fields – a virtual address and a physical bank number. The virtual address is represented by the lower 13 bits and the physical bank by the upper 5 bits. The lower 3 bits of the physical bank number (bits 13, 14, 15) represent the virtual bank number (Table 5-1). Thus if bits 13, 14, and 15 are all 0s, the virtual bank selected is 0. The user should calculate the relocation constant according to Table 5-2. He can then deposit this constant in the relocation register associated with virtual bank 0 (Table 5-1).

Table 5-1 Unibus Address Assignments

Virtual Address	Virtual Bank	Relocation Register	Descriptor Register
160000-177776	7	172356	172316
140000-157776	6	172354	172314
120000-137776	5	172352	172312
100000-117776	4	172350	172310
060000-077776	3	172346	172306
040000-057776	2	172344	172304
020000-037776	1	172342	172302
000000-017776	0	172340	172300

Table 5-2 Relocation Constants

Physical Bank Number	Relocation Constant	Physical Bank Number	Relocation Constant
37	007600	17	003600
36	007400	16	003400
35	007200	15	003200
34	007000	14	003000
33	006600	13	002600
32	006400	12	002400
31	006200	11	002200
30	006000	10	002000
27	005600	7	001600
26	005400	6	001400
25	005200	5	001200
24	005000	4	001000
23	004600	3	000600
22	004400	2	000400
21	004200	1	000200
20	004000	0	000000

One relocation register exists for each of the eight virtual banks. In addition to the relocation registers, each bank has its own descriptor register which provides information regarding the types of access allowed (read-only, read or write, or no access).

The memory management logic also provides various forms of protection against unauthorized access. The corresponding descriptor register must be set up along with the relocation register to allow access anywhere within the 4K bank.

For example, assume a user wishes to access location 533720g. The normal access capability of the console is 0 to 28K. This address (533720) is between the 28K limit and the I/O page (760000-777776), and consequently must be accessed as a relocated virtual address, with memory management enabled. The virtual address is 13720 in physical bank 25 and is derived as follows.

All locations in bank 25 may be accessed through virtual addresses 000000–017776. The relocation and descriptor registers in the processor are still accessible since their addresses are within the I/O page. (Note that access to the I/O page is not automatically relocated with memory management, while access to the I/O page is automatically relocated when memory management is not used.)

The relocation constant for physical bank 25 is 005200. This constant is added in the relocation unit to the virtual address, as shown, yielding 533720.

013720	Virtual address
<u>520000</u>	Relocated constant (Table 5-2)
533720	Physical address

The Unibus addresses of the relocation registers and the descriptor registers are given in Table 5-1. The relocation constant to be loaded into the relocation register for each 4K bank is provided in Table 5-2. The data to be loaded in the descriptor register to provide read/write access to the full 4K is always 077406.

The Unibus address of the control register to enable memory management is 177572. This register is loaded with the value 000001 to enable memory management, and loaded with 0 to disable it.

To complete the example previously described (accessing location 533720), the console routine would be as follows:

```

@L      172340      /Access relocation register for virtual bank 0.
@D      5200        /Deposit code for physical bank 25.
@L      172356      /Access relocation register for virtual bank 7.
@D      7600        /Deposit code for the I/O page.
@L      172300      /Access descriptor register, virtual bank 0.
@D      77406       /Deposit code for read/write access to 4K.
@L      172316      /Access descriptor register, virtual bank 7.
@D      77406       /Deposit code for read/write access to 4K.
@L      177572      /Access control register.
@D      1           /Enable memory management.
@L      13720       /Load virtual address of location desired.
@E                                     /Examine the data in location 533720.
                                     /Data will be displayed.

```

5.6 CONSTRAINTS

Loading a new relocation constant into the relocation register for virtual bank 0 will cause virtual addresses 000000–017776 to access the new physical bank. A second bank can be made accessible by loading the relocation constant and descriptor data into the relocation and descriptor registers for virtual bank 1 and accessing the location through virtual address 020000–037776. Seven banks are accessible in this manner, by loading the proper constants, setting up the descriptor data, and selecting the proper virtual address. Bank 7 (I/O page) must remain relocated to physical bank 37 as it is accessed by the CPU to execute the console emulator routine.

Memory management is disabled by clearing (loading with 0s) control register 177572. It should always be disabled prior to typing a boot command.

The start command automatically disables memory management and the CPU begins executing at the physical address corresponding to the address specified by the previous load address command. Pressing the boot switch automatically disables memory management. The contents of the relocation registers are not modified.

The HALT/CONT switch has no effect on memory management.

CHAPTER 6 DIAGNOSTICS

6.1 GENERAL

The diagnostics in this chapter are standard for the M9312 when used in all PDP-11 computers. Paragraph 6.2 explains the diagnostics used in lower order systems such as the PPD-11/04 and 11/34, where the console emulator routine and diagnostics are to be used. An explanation of switch settings (S1-1, and S1-3 through S1-10) necessary to select specific routines is contained in Paragraphs 2.9 and 3.1. Paragraph 6.3 explains the diagnostics used for PDP-11/60 and 11/70 computers. No console emulator routine is present when used with these systems.

NOTE

LO ROM ENA H jumper W-8 must be out in order to run diagnostics and/or the console emulator routine.

6.2 DIAGNOSTICS

An explanation of the seven CPU and memory diagnostic tests follows. Three types of tests are included in the M9312 diagnostics:

1. Primary CPU tests
2. Secondary CPU tests
3. Memory test

Primary CPU Tests

The primary CPU tests exercise all unary and double operand instructions with all source modes. These tests do not modify memory. If a failure is detected, a branch-self (BR) will be executed. The run light will stay on, because the processor will hang in a loop. If no failure is detected in tests 1-4, the processor will emerge from the last test and enter the register display routine (console emulator).

Test 1 - Single Operand Test - This test executes all single operand instructions using destination mode 0. The basic objective is to verify that all single operand instructions operate; it also provides a cursory check on the operation of each instruction, while ensuring that the CPU decodes each instruction in the correct manner.

Test 1 tests the destination register in its three possible states: zero, negative, and positive. Each instruction operates on the register contents in one of four ways.

1. Data will be changed via a direct operation, i.e., increment, clear, decrement, etc.
2. Data will be changed via an indirect operation, i.e., arithmetic shifts, add carry, and subtract carry.

3. Data will be unchanged, but operated upon via a direct operation, i.e., clear a register already containing zeros.
4. Data will be unchanged but examined via a non-modifying instruction (TEST).

NOTE

When operating upon data in an indirect manner, the data is modified by the state of the appropriate condition code. Arithmetic shift will move the C bit into or out of the destination. This operation, when performed correctly, implies that the C bit was set correctly by the previous instruction. There are no checks on the data integrity prior to the end of the test. However, a check is made on the end result of the data manipulation. A correct result implies that all instructions manipulated the data in the correct way. If the data is incorrect, the program will hang in a program loop until the machine is halted.

Test 2 – Double Operand, All Source Modes – This test verifies all double operand, general, and logical instructions, each in one of the seven addressing modes (excludes mode 0). Thus, two operations are checked: the correct decoding of each double operand instruction, and the correct operation of each addressing mode for the source operand.

Each instruction in the test must operate correctly in order for the next instruction to operate. This interdependence is carried through to the last instruction (bit test) where, only through the correct execution of all previous instructions, a data field is examined for a specific bit configuration. Thus, each instruction prior to the last serves to set up the pointer to the test data.

Two checks on instruction operation are made in test 2. One check, a branch on condition, is made following the compare instruction, while the second is made as the last instruction in the test sequence.

Since the GO-NO GO tests reside in ROM memory, all data manipulation (modification) must be performed in destination mode 0 (register contains data). The data and addressing constants used by test 2 are contained within the ROM.

It is important to note that two different types of operations must execute correctly in order for this test to operate:

1. Those instructions that participate in computing the final address of the data mask for the final bit test instruction.
2. Those instructions that manipulate the test data within the register to generate the expected bit pattern.

Detection of an error within this test results in a program loop.

Test 3 – Jump Test Modes 1, 2, and 3 – The purpose of this test is to ensure correct operation of the jump instruction. The test is constructed so that only a jump to the expected instruction will provide the correct pointer for the next instruction.

There are two possible failure modes that can occur in this test:

1. The jump addressing circuitry will malfunction causing a transfer of execution to an incorrect instruction sequence or non-existent memory.
2. The jump addressing circuitry will malfunction in such a way as to cause the CPU to loop.

The latter case is a logical error indicator. The former, however, may manifest itself as an after-the-fact error. For example, if the jump causes control to be given to other routines within the M9312, the interdependent instruction sequences would probably cause a failure to eventually occur. In any case, the failing of the jump instruction will eventually cause an out of sequence or illogical event to occur. This in itself is a meaningful indicator of a malfunctioning CPU.

This test contains a jump mode 2 instruction that is not compatible across the PDP-11 line. However, it will operate on any PDP-11 within this test, due to the unique programming of the instruction within test 3. Before illustrating the operation, it is important to understand the differences of the jump mode 2 between machines.

On the PDP-11/05, 11/10, 11/15, and 11/20 processors, for the jump mode 2 [JMP(R)+C, the register (R) is incremented by 2 prior to execution of the jump. On the PDP-11/04, 11/34, 11/35, 11/40, 11/45, 11/50, 11/55, and 11/70 processors, (R) is used as a jump address and incremented by 2 after execution of the jump.

In order to overcome this incompatibility, the JMP(R)+ is programmed with (R) pointing back on the jump itself. On PDP-11/05, 11/10, 11/15, and 11/20 processors, execution of the instruction would cause (R) to be incremented to point to the following instruction, effectively continuing a normal execution sequence.

On the PDP-11/04, 11/34, 11/35, 11/40, 11/45, 11/50, 11/55, and 11/70 processors, the use of the initial value of (R) will cause the jump to loop back on itself. However, correct operation of the auto-increment will move (R) to point to the next instruction following the initial jump. The jump will then be executed again. However, the destination address will be the next instruction in sequence.

Test 4 - Single Operand, Non-Modifying Byte Test - This test focuses on the one single operand instruction, the TST. TST is a special case in the CPU execution flow since it is a non-modifying operation. Test 4 also tests the byte operation of this instruction. The TSTB instruction will be executed in mode 1 (register deferred) and mode 2 (register deferred, auto-increment).

The TSTB is programmed to operate on data which has a negative value most significant byte and a zero (not negative) least significant byte.

In order for this test to operate properly, the TSTB on the low byte must first be able to access the even addressed byte and then set the proper condition codes. The TSTB is then re-executed with the auto-increment facility. After the auto-increment, the addressing register should be pointing to the high byte of the test data. Another TSTB is executed on what should be the high byte. The N bit of the condition codes should be set by this operation.

Correct execution of the last TSTB implies that the auto-increment recognized that a byte operation was requested, thereby only incrementing the address in the register by one, rather than two. If the correct condition code has not been set by the associated TSTB instruction, the program will loop.

Upon successful completion of test 4, the register display routine is enabled. This routine will be followed by a prompt character (@) on the next line.

An example of a typical printout follows.

	XXXXXX	XXXXXX	XXXXXX	XXXXXX
@	R0	R4	R6	R5
Prompt Character			(Stack Pointer)	(Old PC)

NOTES

1. X signifies an octal number (0-7).
2. Whenever there is a power-up routine or the boot switch is released on PDP-11/04 and PDP-11/34 machines, the PC at this time will be stored in R5. The contents of R5 are then printed as the old PC shown in the example.
3. The prompting character string indicates that diagnostics have been run and the processor is operating.

Secondary CPU and Memory Tests

The secondary CPU tests modify memory and involve the use of the stack pointer. The JMP and JSR instructions and all destination modes are tested. If a failure is detected, these tests, unlike the primary tests, will execute a halt.

Secondary CPU and memory diagnostics are run immediately after test 4 when they have been evoked by means other than the console emulator, provided that the correct microswitches have been set. If the console emulator has been entered at the completion of test 4, the secondary CPU and memory diagnostics will be run when the appropriate boot command is given.

The M9312 reacts to a false boot command (an invalid address code) by returning to the console emulator routine. This should not be interpreted as a diagnostic test failure.

Test 6 – Double Operand, Modifying, Byte Test – The objective of this test is to verify that the double-operand, modifying instructions will operate in the byte mode. Test 6 contains three subtests:

1. Test source mode 2, destination mode 1, odd and even bytes
2. Test source mode 3, destination mode 2
3. Test source mode 0, destination mode 3, even byte.

The move byte (MOVB), bit clear byte (BICB), and bit set byte (BISB) are used within test 6 to verify the operation of the modifying double-operand functions.

Since modifying instructions are under test, memory must be used as a destination for the test data. Test 6 uses location 500 as a destination address. Later, in test 7 and the memory test, location 500 is used as the first available storage for the stack.

Note that since test 6 is a byte test, location 500 implies that both 500 and 501 are used for the byte tests (even and odd, respectively). Thus, in the word of data at 500, odd and even bytes are caused to be all 0s and then all 1s alternately throughout the test. Each byte is modified independently of the other.

Test 7 – JSR Test – The JSR is the first test in the GO-NO GO sequence that utilizes the stack. The jump subroutine command (JSR) is executed in modes 1 and 6. After the JSR is executed, the subroutine which was given control will examine the stack to ensure that the correct data was placed in the correct stack location (500). The routine will also ensure that the line back register points to the correct address. Any errors detected in this test will result in a halt.

Test 8 – Dual Addressing and Data Check – Finally the memory test performs both dual addressing and data check of all the available memory on the system below 28K. This test will leave all of memory clear. Like the secondary tests the memory test will halt when an error is detected. At the time the memory error halt is executed, R4 will contain the address at which the failure was detected. R0 will contain the failing data pattern and R6 will contain the expected data pattern. Thus after a memory failure has occurred, the user can enter the console emulator and have this information printed out immediately by display routine. (See section on console emulator.)

6.3 DIAGNOSTICS (PDP-11/60 AND 11/70)

The M9312 provides basic diagnostic tests for the CPU, memory, and cache when used with PDP-11/60 and PDP-11/70 computers. All diagnostic tests reside in ROM memory locations 765000 through 765776 (console emulator routine is eliminated.) These diagnostics test the basic CPU including the branches, the registers, all addressing modes, and many of the instructions in the PDP-11 repertoire. Memory from virtual address 1000 to the highest available address up to 28K will also be checked. After main memory has been verified, with the cache off, the cache memory will be tested to verify that hits occur properly. Main memory will be scanned again to ensure that the cache is working properly throughout the 28K of memory to be used in the boot operation. If one of the cache memory tests fails, the operator can attempt to boot the system anyway by pressing continue. This will cause the program to force misses in both groups of the cache before going to the bootstrap section of the program. The following is a list of M9312 diagnostic tests.

TEST 1	This test verifies the unconditional branch
TEST 2	Test CLR, MODE 0, and BMI, BVS, BHI, BLT, BLOS
TEST 3	Test DEC, MODE 0, and BPL, BEQ, BGE, BLE
TEST 4	Test ROR, MODE 0, and BVC, BHIS, BNE
TEST 5	Test register data path
TEST 6	Test ROL, BCC, BLT
TEST 7	Test ADD, INC, COM, and BCS, BLE
TEST 10	Test ROR, DEC, BIS, ADD, and BLO
TEST 11	Test COM, BIC, and BGT, BLE
TEST 12	Test SWAB, CMP, BIT, and BNE, BGT
TEST 13	Test MOVB, SOB, CLR, TST and BPL, BNG
TEST 14	Test JSR, RTS, RTI, and JMP
TEST 15	Test main memory from virtual 001000 to last address Cache memory diagnostic tests
TEST 16	Test cache data memory
TEST 17	Test memory with the data cache on

Diagnostic Test Descriptions

Test 1 – Verify the Unconditional Branch

The registers and condition codes are all undefined when this test is entered and they should remain that way upon completion of this test.

Test 2 – Test CLR, MODE 0, and BMI, BVS, BHI, BLT, BLOS

The registers and condition codes are all undefined when this test is entered. Upon completion of this test, the SP (R6) should be zero and only the Z flip-flop will be set.

Test 3 – Test DEC, MODE 0, and BPL, BEQ, BGE, BLE

Upon entering this test, the condition codes are: N = 0, Z = 1, V = 0, and C = 0.

The registers are: R0 = ?, R1 = ?, R2 = ?, R3 = ?, R4 = ?, R5 = ?, and SP = 000000.

Upon completion of this test, the condition codes will be: N = 1, Z = 0, V = 0, and C = 0.

The registers affected by the test are: SP = 177777.

Test 4 – Test ROR, MODE 0, and BVC, BHIS, BNE

Upon entering this test, the condition codes are: N = 1, Z = 0, V = 0, and C = 0.

The registers are: R0 = ?, R1 = ?, R2 = ?, R3 = ?, R4 = ?, R5 = ?, and SP = 177777.

Upon completion of this test, the condition codes will be: N = 0, Z = 0, V = 1, and C = 1.

The registers affected by the test are: SP = 077777.

Test 5 – Test Register Data Path

Upon entering this test, the condition codes are: N = 0, Z = 0, V = 1, and C = 1.

The registers are: R0 = ?, R1 = ?, R2 = ?, R3 = ?, R4 = ?, R5 = ?, and SP = 077777.

Upon completion of this test, the condition codes will be: N = 0, Z = 1, V = 0, and C = 0.

The registers are left as follows: R0 = 125252, R1 = 000000, R2 = 125252, R3 = 125252, R4 = 125252, R5 = 125252, and SP = 125252.

Test 6 – Test ROL, BCC, BLT

When this test is entered, the condition codes are: N = 0, Z = 1, V = 0, and C = 0.

The registers are: R0 = 125252, R1 = 000000, R2 = 125252, R3 = 125252, R4 = 125252, R5 = 125252, SP = 125252.

Upon completion of this test, the condition codes are: N = 0, Z = 0, V = 1, and C = 1.

The registers are left unchanged except for R2 which should now equal 052524.

Test 7 – Test ADD, INC, COM, and BCS, BLE

When this test is entered, the condition codes are: N = 0, Z = 0, V = 1, and C = 1.

The registers are: R0 = 125252, R1 = 000000, R2 = 052524, R3 = 125252, R4 = 125252, R5 = 125252, SP = 125252.

Upon completion of this test, the condition codes are: N = 0, Z = 1, V = 0, and C = 0.

The registers are left unchanged except for R3 which now equals 000000, and R1 which is also 000000.

Test 10 – Test ROR, DEC, BIS, ADD, and BLO

When this test is entered, the condition codes are: N = 0, Z = 1, V = 0, and C = 0.

The registers are: R0 = 125252, R1 = 000000, R2 = 052524, R3 = 000000, R4 = 125252, R5 = 125252, and SP = 125252.

Upon completion of this test, the condition codes are: N = 1, Z = 0, V = 0, and C = 0.

The registers are left unchanged except for R1 which should equal 177777, and R4 which should now equal 052525.

Test 11 – Test COM, BIC, and BGT, BLE

When this test is entered, the condition codes are: N = 1, Z = 0, V = 0, and C = 0.

The registers are: R0 = 125252, R1 = 177777, R2 = 052524, R3 = 000000, R4 = 052525, R5 = 125252, and SP = 125252.

Upon completion of this test, the condition codes are: N = 0, Z = 0, V = 1, and C = 1. The registers are left unchanged except for R0 which should now equal 052525, and R1 which should now equal 052524.

Test 12 – Test SWAB, CMP, BIT, and BNE, BGT

When this test is entered, the condition codes are: N = 0, Z = 0, V = 1, and C = 1.

The registers are: R0 = 052525, R1 = 052524, R2 = 052524, R3 = 000000, R4 = 052525, R5 = 125252, SP = 125252.

Upon completion of this test, the condition codes are: N = 0, Z = 0, V = 0, and C = 1.

The registers are now: R0 = 052525, R1 = 052125, R2 = 052524, R3 = 000000, R4 = 052525, R5 = 052525, SP = 125252.

Test 13 – Test MOVB, SOB, CLR, TST and BPL, BNE

When this test is entered, the condition codes are: N = 0, Z = 0, V = 0, and C = 1.

The registers are: R0 = 052525, R1 = 052125, R2 = 052524, R3 = 000000, R4 = 052525, R5 = 052525, and SP = 125252.

Upon completion of this test, the condition codes are: N = 0, Z = 1, V = 0, and C = 0.

R0 is decremented by an SOB instruction to 000000; R1 is cleared and then incremented around to 000000.

Test 14 – Test JSR, RTS, RTI, JMP

This test first sets the stack pointer to 000776, and then verifies that JSR, RTS, RTI, and JMP all work properly.

On entry to this test, the stack pointer (SP) is initialized to 000776 and is left that way on exit.

Test 15 – Test Main Memory from 1000 to Highest Available Address up to 28K

This test will test main memory with the cache disabled, from virtual address 001000 to the last address (up to 28K). The memory is sized before testing begins. If the data does not compare properly, the test will halt at either 165516 or 165536. If a parity error occurs, the test will halt at address 165750, with PC + 2 on the stack.

In this test the registers are initialized as follows: R0 = 001000, R1 = DATA READ, R2 = 001000, R3 = 177746 (cache control register), R4 = count value, R5 = last memory address, SP = 000776.

The following two tests are cache memory tests. If either of them fails to run successfully it will come to a halt in the M9312 ROM. If you desire to try to boot your system anyway, you can press continue and the program will force misses in both groups of the cache and go to the bootstrap that has been selected.

Test 16 – Test Cache Data Memory

This test will check the data memory in the cache, on the PDP-11/60. There is only one group (1K), on PDP-11/70 there are two groups, (1/2K) each. The test loads 0552525 into an address, complements it twice and then reads the data, then it checks to ensure that the data was a hit. Then the sequence is repeated on the same address with 125252 as the data. All cache memory data locations are tested in this way. If either group fails and the operator presses continue the program will try to boot with the cache disabled.

The registers are initialized as follows for this test: R0 = 4000 (address), R1 = 2 (count), R2 = 1000 (count), R3 = 177746 (control register), R4 = 125252 (pattern), R5 = (last memory address), SP = 000776 (flag of zero pushed on stack).

Test 17 – Test Memory with the Data Cache On

This test checks virtual memory from 001000 thru last address to ensure that you can get hits all the way up through main memory. On the PDP-11/70, it starts with group 1 enabled, then tests group 0, and finally checks memory with both groups enabled. On the PDP-11/60, the test is done with the whole cache enabled.

Upon entry the registers will be set up as follows: R0 = 001000 (address), R1 = 3 (pass count), R2 = (first address), R3 = 177746 (control register), R5 = (last memory address), SP = 775

Upon completion of this test main memory from virtual address 001000 thru last address will contain its own virtual address.

APPENDIX A M9312 JUMPERS

A.1 INTRODUCTION

The M9312 Bootstrap/Terminator Module is compatible with any PDP-11 system through the use of 12 jumpers (W-1 through W-12.) Table A-1 explains the function of these jumpers. Table A-2 shows necessary jumper configurations for various PDP-11 systems.

Table A-1 Jumper Explanation

Jumper	Function
W1	Connects Pull Up for BUS BG6 H (When in)
W2	Connects Pull Up for BUS BG7 H (When in)
W3	Connects Pull Up for BUS NPG H (When in)
W4	Connects Pull Up for BUS BG5 H (When in)
W5	Connects Pull Up for BUS BG4 H (When in)
W6	Connects BUF VECTOR L to finger BD1 (IN for PDP-11/70)
W7	RESERVED (Always in)
W8	Connects LO ROM ENABLE H (When out)
W9, W10	Install for power-up boot to 773024 ₍₈₎ (IN for all CPUs except 11/60)
W11, W12	Install for power-up boot to 773224 ₍₈₎ (IN for PDP-11/60 only)

Table A-2 Jumper Configurations

PDP-11 Systems	Jumpers											
	W1	W2	W3	W4	W5	W6	W7	W8	W9	W10	W11	W12
PDP-11/04/34/34A (Modified Unibus Device Machine) with the M9312 in slot AB2, 3, 4 of processor backplane	OUT	OUT	OUT	OUT	OUT	OUT	IN	OUT	IN	IN	OUT	OUT
PDP-11/70 with M9312 in slot EF1 of processor backplane (See note)	IN	IN	IN	IN	IN	IN	IN	OUT	IN	IN	OUT	OUT
PDP-11/60 with M9312 in the last AB slot of the last memory backplane	OUT	OUT	OUT	OUT	OUT	OUT	IN	OUT	OUT	OUT	IN	IN
Other Unibus CPUs with an M9312, or an M9312 in place of an M9301 or equivalent	IN	IN	IN	IN	IN	OUT	IN	IN	IN	IN	OUT	OUT

NOTES

If a Unibus repeater is used in the system, the M9312 must be installed on the processor side of the repeater.

For boot on power-up the 11/70 requires the following.

- 1. 7010329 backplane ECO 8 (wire list Rev J or later)**
- 2. M8130 ECO's 1, 2 and 3 (CS Rev C or later)
Jumpers set as follows: W1-IN, W2-OUT, W3-IN, W4-OUT, W5-OUT, W6-OUT, W7-OUT, W8-IN, W9-OUT**
- 3. M8138 ECO 5 (CS Revs C1 or E or later)**
- 4. M9312 ECO 1 (CS Rev B or later)**

APPENDIX B M9312 ROMs

The M9312, through the use of socketed ROMs, can boot most PDP-11 peripheral devices, run diagnostic routines or execute a console emulator routine. The Address Offset Switch Bank (Paragraph 2.9 and Appendix C) is used to select one or more of these functions. Five sockets are used to accept ROMs with these various routines. The console emulator and diagnostic ROM socket (E20) accepts ROMs which contain either a console emulator and diagnostic routine or just a diagnostic routine for the PDP-11/60 and 11/70. The last two characters in the pattern number for these ROMs will always be "F1." The other four sockets (locations E32, E33, E34, and E35) accept ROMs which contain bootstrap programs. The last two characters of the pattern number for boot ROMs will always be "A9." Although it is not required that a particular device boot ROM go in a particular socket, the order in which these sockets are filled is important. Table B-1 shows the necessary installation order for Boot ROMs.

Table B-1 Boot ROM Installation Order

Order of Installation	ROM Socket #	Location #
First Boot ROM*	E35	1
Second Boot ROM	E33	2
Third Boot ROM	E34	3
Fourth Boot ROM	E32	4

*On PDP-11/60 if only one ROM, then it must be installed in ROM location #2 to do a power-up boot.

APPENDIX C

M9312 ADDRESS OFFSET SWITCH BANK

C.1 INTRODUCTION

Tables C-1 through C-11 contain the necessary information to boot a particular device either on power-up boot, pushbutton boot, or console load address start sequence. A more detailed explanation of these switches and their functions may be found in Paragraphs 2.9 and 3.2, Table 3-1, Figure 2-11, and Appendix F.

Table C-1 ROM P/N 23-751A9

Device to be Booted	ROM Location from App B	Diagnostic	Unit	Starting Address*	Switch Settings S1-for Power-Up Boot or Push-Button Boot of Device										SWR Code
					1	2	3	4	5	6	7	8	9	10	
RL01	ROM 1	NO	0	173004	OFF	†	OFF	OFF	OFF	OFF	OFF	OFF	ON	OFF	NA
RL01	ROM 1	YES	0	173006	OFF	†	OFF	OFF	OFF	OFF	OFF	OFF	ON	ON	012
RL01	ROM 2	NO	0	173204	OFF	†	OFF	ON	OFF	OFF	OFF	OFF	ON	OFF	NA
RL01	ROM 2	YES	0	173206	OFF	†	OFF	ON	OFF	OFF	OFF	OFF	ON	ON	212
RL01	ROM 3	NO	0	173404	OFF	†	ON	OFF	OFF	OFF	OFF	OFF	ON	OFF	NA
RL01	ROM 3	YES	0	173406	OFF	†	ON	OFF	OFF	OFF	OFF	OFF	ON	ON	412
RL01	ROM 4	NO	0	173604	OFF	†	ON	ON	OFF	OFF	OFF	OFF	ON	OFF	NA
RL01	ROM 4	YES	0	173606	OFF	†	ON	ON	OFF	OFF	OFF	OFF	ON	ON	612

*The starting address for the console load address and start sequence.

† S1-2: when ON, power-up boot is enabled; when OFF, power-up boot disabled. (Must be OFF for PDP-11/60. See PDP-11/60 documentation for power-up boot.)

NOTES

If diagnostics are to be run, a CPU diagnostic ROM must be in location E20, and jumper W8 must be out.

When booting from the console emulator, a device mnemonic and unit number are required. If unit number is not entered, it is assumed to be zero. Listed below are the device mnemonic and unit numbers supported by this ROM, and the device CSR address assumed by the boot code.

Device	Mnemonic	Unit	CSR
RL01	DL	0-3	774400

Table C-2 ROM P/N 23-752A9

Device to be Booted	ROM Location from App B	Diagnostic	Unit	Starting Address*	Switch Settings S1 -for Power-Up Boot or Push-Button Boot of Device										SWR Code
					1	2	3	4	5	6	7	8	9	10	
RK06/07	ROM 1	NO	0	173004	OFF	†	OFF	OFF	OFF	OFF	OFF	OFF	ON	OFF	NA
RK06/07	ROM 1	YES	0	173006	OFF	†	OFF	OFF	OFF	OFF	OFF	OFF	ON	ON	012
RK06/07	ROM 2	NO	0	173204	OFF	†	OFF	ON	OFF	OFF	OFF	OFF	ON	OFF	NA
RK06/07	ROM 2	YES	0	173206	OFF	†	OFF	ON	OFF	OFF	OFF	OFF	ON	ON	212
RK06/07	ROM 3	NO	0	173404	OFF	†	ON	OFF	OFF	OFF	OFF	OFF	ON	OFF	NA
RK06/07	ROM 3	YES	0	173406	OFF	†	ON	OFF	OFF	OFF	OFF	OFF	ON	ON	412
RK06/07	ROM 4	NO	0	173604	OFF	†	ON	ON	OFF	OFF	OFF	OFF	ON	OFF	NA
RK06/07	ROM 4	YES	0	173606	OFF	†	ON	ON	OFF	OFF	OFF	OFF	ON	ON	612

*The starting address for the console load address and start sequence.

† S1-2: when ON, power-up boot is enabled; when OFF, power-up boot disabled. (Must be OFF for PDP-11/60. See PDP-11/60 documentation for power-up boot.)

NOTES

If diagnostics are to be run, a CPU diagnostic ROM must be in location E20, and jumper W8 must be out.

When booting from the console emulator, a device mnemonic and unit number are required. If unit number is not entered, it is assumed to be zero. Listed below are the device mnemonic and unit numbers supported by this ROM, and the device CSR address assumed by the boot code.

Device	Mnemonic	Unit	CSR
RK06/07	DM	0-7	777440

Table C-3 ROM P/N 23-753A9

Device to be Booted	ROM Location from App B	Diagnostic	Unit	Starting Address*	Switch Settings S1 -for Power-Up Boot or Push-Button Boot of Device										SWR Code
					1	2	3	4	5	6	7	8	9	10	
RX01	ROM 1	NO	0	173004	OFF	†	OFF	OFF	OFF	OFF	OFF	OFF	ON	OFF	NA
RX01	ROM 1	YES	0	173006	OFF	†	OFF	OFF	OFF	OFF	OFF	OFF	ON	ON	012
RX01	ROM 2	NO	0	173204	OFF	†	OFF	ON	OFF	OFF	OFF	OFF	ON	OFF	NA
RX01	ROM 2	YES	0	173206	OFF	†	OFF	ON	OFF	OFF	OFF	OFF	ON	ON	212
RX01	ROM 3	NO	0	173404	OFF	†	ON	OFF	OFF	OFF	OFF	OFF	ON	OFF	NA
RX01	ROM 3	YES	0	173406	OFF	†	ON	OFF	OFF	OFF	OFF	OFF	ON	ON	412
RX01	ROM 4	NO	0	173604	OFF	†	ON	ON	OFF	OFF	OFF	OFF	ON	OFF	NA
RX01	ROM 4	YES	0	173606	OFF	†	ON	ON	OFF	OFF	OFF	OFF	ON	ON	612

*The starting address for the console load address and start sequence.

†S1-2: when ON, power-up boot is enabled; when OFF, power-up boot disabled. (Must be OFF for PDP-11/60. See PDP-11/60 documentation for power-up boot.)

NOTES

If diagnostics are to be run, a CPU diagnostic ROM must be in location E20, and jumper W8 must be out.

When booting from the console emulator, a device mnemonic and unit number are required. If unit number is not entered, it is assumed to be zero. Listed below are the device mnemonic and unit numbers supported by this ROM, and the device CSR address assumed by the boot code.

Device	Mnemonic	Unit	CSR
RX01	DX	0-1	777170

Table C-4 ROM P/N 23-755A9

Device to be Booted	ROM Location from App B	Diagnostic	Unit	Starting Address*	Switch Settings S1 - for Power-Up Boot or Push-Button Boot of Device										SWR Code
					1	2	3	4	5	6	7	8	9	10	
RP02/03	ROM 1	NO	0	173004	OFF	†	OFF	OFF	OFF	OFF	OFF	OFF	ON	OFF	NA
RP02/03	ROM 1	YES	0	173006	OFF	†	OFF	OFF	OFF	OFF	OFF	OFF	ON	ON	012
RP02/03	ROM 2	NO	0	173204	OFF	†	OFF	ON	OFF	OFF	OFF	OFF	ON	OFF	NA
RP02/03	ROM 2	YES	0	173206	OFF	†	OFF	ON	OFF	OFF	OFF	OFF	ON	ON	212
RP02/03	ROM 3	NO	0	173404	OFF	†	ON	OFF	OFF	OFF	OFF	OFF	ON	OFF	NA
RP02/03	ROM 3	YES	0	173406	OFF	†	ON	OFF	OFF	OFF	OFF	OFF	ON	ON	412
RP02/03	ROM 4	NO	0	173604	OFF	†	ON	ON	OFF	OFF	OFF	OFF	ON	OFF	NA
RP02/03	ROM 4	YES	0	173606	OFF	†	ON	ON	OFF	OFF	OFF	OFF	ON	ON	612
RP04/05/06 RM02/03	ROM 1	NO	0	173050	OFF	†	OFF	OFF	OFF	ON	OFF	ON	OFF	OFF	NA
RP04/05/06 RM02/03	ROM 1	YES	0	173052	OFF	†	OFF	OFF	OFF	ON	OFF	ON	OFF	ON	056
RP04/05/06 RM02/03	ROM 2	NO	0	173250	OFF	†	OFF	ON	OFF	ON	OFF	ON	OFF	OFF	NA
RP04/05/06 RM02/03	ROM 2	YES	0	173252	OFF	†	OFF	ON	OFF	ON	OFF	ON	OFF	ON	256
RP04/05/06 RM02/03	ROM 3	NO	0	173450	OFF	†	ON	OFF	OFF	ON	OFF	ON	OFF	OFF	NA
RP04/05/06 RM02/03	ROM 3	YES	0	173452	OFF	†	ON	OFF	OFF	ON	OFF	ON	OFF	ON	456
RP04/05/06 RM02/03	ROM 4	NO	0	173650	OFF	†	ON	ON	OFF	ON	OFF	ON	OFF	OFF	NA
RP04/05/06 RM02/03	ROM 4	YES	0	173652	OFF	†	ON	ON	OFF	ON	OFF	ON	OFF	ON	656

*The starting address for the console load address and start sequence.

† S1-2: when ON, power-up boot is enabled; when OFF, power-up boot disabled. (Must be OFF for PDP-11/60. See PDP-11/60 documentation for power-up boot.)

NOTES

If diagnostics are to be run, a CPU diagnostic ROM must be in location E20, and jumper W8 must be out.

When booting from the console emulator, a device mnemonic and unit number are required. If unit number is not entered, it is assumed to be zero. Listed below are the device mnemonic and unit numbers supported by this ROM, and the device CSR address assumed by the boot code.

Device	Mnemonic	Unit	CSR
RP02/03	DP	0-7	776714
RP04/05/06 RM02/03	DB	0-7	776700

Table C-5 ROM P/N 23-756A9

Device to be Booted	ROM Location from App B	Diagnostic	Unit	Starting Address*	Switch Settings S1 - for Power-Up Boot or Push-Button Boot of Device										SWR Code
					1	2	3	4	5	6	7	8	9	10	
RK03/05/05J	ROM 1	NO	0	173004	OFF	†	OFF	OFF	OFF	OFF	OFF	OFF	ON	OFF	NA
RK03/05/05J	ROM 1	NO	2	173164	OFF	†	OFF	OFF	ON	ON	ON	OFF	ON	OFF	NA
RK03/05/05J	ROM 1	YES	0	173006	OFF	†	OFF	OFF	OFF	OFF	OFF	OFF	ON	ON	012
RK03/05/05J	ROM 2	NO	0	173204	OFF	†	OFF	ON	OFF	OFF	OFF	OFF	ON	OFF	NA
RK03/05/05J	ROM 2	NO	2	173364	OFF	†	OFF	ON	ON	ON	ON	OFF	ON	OFF	NA
RK03/05/05J	ROM 2	YES	0	173206	OFF	†	OFF	ON	OFF	OFF	OFF	OFF	ON	ON	212
RK03/05/05J	ROM 3	NO	0	173404	OFF	†	ON	OFF	OFF	OFF	OFF	OFF	ON	OFF	NA
RK03/05/05J	ROM 3	NO	2	173564	OFF	†	ON	OFF	ON	ON	ON	OFF	ON	OFF	NA
RK03/05/05J	ROM 3	YES	0	173406	OFF	†	ON	OFF	OFF	OFF	OFF	OFF	ON	ON	412
RK03/05/05J	ROM 4	NO	0	173604	OFF	†	ON	ON	OFF	OFF	OFF	OFF	ON	OFF	NA
RK03/05/05J	ROM 4	NO	2	173764	OFF	†	ON	ON	ON	ON	ON	OFF	ON	OFF	NA
RK03/05/05J	ROM 4	YES	0	173606	OFF	†	ON	ON	OFF	OFF	OFF	OFF	ON	ON	612
TU55/56	ROM 1	NO	0	173034	OFF	†	OFF	OFF	OFF	OFF	ON	ON	ON	OFF	NA
TU55/56	ROM 1	YES	0	173036	OFF	†	OFF	OFF	OFF	OFF	ON	ON	ON	ON	042
TU55/56	ROM 2	NO	0	173234	OFF	†	OFF	ON	OFF	OFF	ON	ON	ON	OFF	NA
TU55/56	ROM 2	YES	0	173236	OFF	†	OFF	ON	OFF	OFF	ON	ON	ON	ON	242
TU55/56	ROM 3	NO	0	173434	OFF	†	ON	OFF	OFF	OFF	ON	ON	ON	OFF	NA
TU55/56	ROM 3	YES	0	173436	OFF	†	ON	OFF	OFF	OFF	ON	ON	ON	ON	442
TU55/56	ROM 4	NO	0	173634	OFF	†	ON	ON	OFF	OFF	ON	ON	ON	OFF	NA
TU55/56	ROM 4	YES	0	173636	OFF	†	ON	ON	OFF	OFF	ON	ON	ON	ON	642

*The starting address for the console load address and start sequence.

†S1-2: when ON, power-up boot is enabled; when OFF, power-up boot disabled. (Must be OFF for PDP-11/60. See PDP-11/60 documentation for power-up boot.)

NOTES

If diagnostics are to be run, a CPU diagnostic ROM must be in location E20, and jumper W8 must be out.

When booting from the console emulator, a device mnemonic and unit number are required. If unit number is not entered, it is assumed to be zero. Listed below are the device mnemonic and unit numbers supported by this ROM, and the device CSR address assumed by the boot code.

Device	Mnemonic	Unit	CSR
RK03/05/05J	DK	0-7	777404
TU55/56	DT	0-7	777342

Table C-6 ROM P/N 23-757A9

Device to be Booted	ROM Location from APP B	Diagnostic	Unit	Starting Address*	Switch Settings S1 - for Power-Up Boot or Push-Button Boot of Device										SWR Code
					1	2	3	4	5	6	7	8	9	10	
TU16	ROM 1	NO	0	173004	OFF	†	OFF	OFF	OFF	OFF	OFF	OFF	ON	OFF	NA
TU16	ROM 1	YES	0	173006	OFF	†	OFF	OFF	OFF	OFF	OFF	OFF	ON	ON	012
TU16	ROM 2	NO	0	173204	OFF	†	OFF	ON	OFF	OFF	OFF	OFF	ON	OFF	NA
TU16	ROM 2	YES	0	173206	OFF	†	OFF	ON	OFF	OFF	OFF	OFF	ON	ON	212
TU16	ROM 3	NO	0	173404	OFF	†	ON	OFF	OFF	OFF	OFF	OFF	ON	OFF	NA
TU16	ROM 3	YES	0	173406	OFF	†	ON	OFF	OFF	OFF	OFF	OFF	ON	ON	412
TU16	ROM 4	NO	0	173604	OFF	†	ON	ON	OFF	OFF	OFF	OFF	ON	OFF	NA
TU16	ROM 4	YES	0	173606	OFF	†	ON	ON	OFF	OFF	OFF	OFF	ON	ON	612

*The starting address for the console load address and start sequence.
 † S1-2: when ON, power-up boot is enabled; when OFF, power-up boot disabled. (Must be OFF for PDP-11/60. See PDP-11/60 documentation for power-up boot.)

NOTES

If diagnostics are to be run, a CPU diagnostic ROM must be in location E20, and jumper W8 must be out.

When booting from the console emulator, a device mnemonic and unit number are required. If unit number is not entered, it is assumed to be zero. Listed below are the device mnemonic and unit numbers supported by this ROM, and the device CSR address assumed by the boot code.

Device	Mnemonic	Unit	CSR
TU16	MM	0-7	772440

Table C-7 ROM P/N 23-758A9

Device to be Booted	ROM Location from App B	Diagnostic	Unit	Starting Address*	Switch Settings S1 - for Power-Up Boot or Push-Button Boot of Device										SWR Code
					1	2	3	4	5	6	7	8	9	10	
TU10 TS03	ROM 1	NO	0	173004	OFF	†	OFF	OFF	OFF	OFF	OFF	OFF	ON	OFF	NA
TU10 TS03	ROM 1	YES	0	173006	OFF	†	OFF	OFF	OFF	OFF	OFF	OFF	ON	ON	012
TU10 TS03	ROM 2	NO	0	173204	OFF	†	OFF	ON	OFF	OFF	OFF	OFF	ON	OFF	NA
TU10 TS03	ROM 2	YES	0	173206	OFF	†	OFF	ON	OFF	OFF	OFF	OFF	ON	ON	212
TU10 TS03	ROM 3	NO	0	173404	OFF	†	ON	OFF	OFF	OFF	OFF	OFF	ON	OFF	NA
TU10 TS03	ROM 3	YES	0	173406	OFF	†	ON	OFF	OFF	OFF	OFF	OFF	ON	ON	412
TU10 TS03	ROM 4	NO	0	173604	OFF	†	ON	ON	OFF	OFF	OFF	OFF	ON	OFF	NA
TU10 TS03	ROM 4	YES	0	173606	OFF	†	ON	ON	OFF	OFF	OFF	OFF	ON	ON	612

*The starting address for the console load address and start sequence.

†S1-2: when ON, power-up boot is enabled; when OFF, power-up boot disabled. (Must be OFF for PDP-11/60. See PDP-11/60 documentation for power-up boot.)

NOTES

If diagnostics are to be run, a CPU diagnostic ROM must be in location E20, and jumper W8 must be out.

When booting from the console emulator, a device mnemonic and unit number are required. If unit number is not entered, it is assumed to be zero. Listed below are the device mnemonic and unit numbers supported by this ROM, and the device CSR address assumed by the boot code.

Device	Mnemonic	Unit	CSR
TU10 TS03	MT	0-7	772522

Table C-8 ROM P/N 23-759A9

Device to be Booted	ROM Location from App B	Diagnostic	Unit	Starting Address*	Switch Settings S1 - for Power-Up Boot or Push-Button Boot of Device										SWR Code
					1	2	3	4	5	6	7	8	9	10	
RS03/04	ROM 1	NO	0	173004	OFF	†	OFF	OFF	OFF	OFF	OFF	OFF	ON	OFF	NA
RS03/04	ROM 1	YES	0	173006	OFF	†	OFF	OFF	OFF	OFF	OFF	OFF	ON	ON	012
RS03/04	ROM 2	NO	0	173204	OFF	†	OFF	ON	OFF	OFF	OFF	OFF	ON	OFF	NA
RS03/04	ROM 2	YES	0	173206	OFF	†	OFF	ON	OFF	OFF	OFF	OFF	ON	ON	212
RS03/04	ROM 3	NO	0	173404	OFF	†	ON	OFF	OFF	OFF	OFF	OFF	ON	OFF	NA
RS03/04	ROM 3	YES	0	173406	OFF	†	ON	OFF	OFF	OFF	OFF	OFF	ON	ON	412
RS03/04	ROM 4	NO	0	173604	OFF	†	ON	ON	OFF	OFF	OFF	OFF	ON	OFF	NA
RS03/04	ROM 4	YES	0	173606	OFF	†	ON	ON	OFF	OFF	OFF	OFF	ON	ON	612

*The starting address for the console load address and start sequence.

† S1-2: when ON, power-up boot is enabled; when OFF, power-up boot disabled. (Must be OFF for PDP-11/60. See PDP-11/60 documentation for power-up boot.)

NOTES

If diagnostics are to be run, a CPU diagnostic ROM must be in location E20, and jumper W8 must be out.

When booting from the console emulator, a device mnemonic and unit number are required. If unit number is not entered, it is assumed to be zero. Listed below are the device mnemonic and unit numbers supported by this ROM, and the device CSR address assumed by the boot code.

Device	Mnemonic	Unit	CSR
RS03/04	DS	0-7	772040

Table C-9 ROM P/N 23-760A9

Device to be Booted	ROM Location from App B	Diagnostic	Unit	Starting Address*	Switch Settings S1 – for Power-Up Boot or Push-Button Boot of Device										SWR Code
					1	2	3	4	5	6	7	8	9	10	
PC05	ROM 1	NO	0	173004	OFF	†	OFF	OFF	OFF	OFF	OFF	OFF	ON	OFF	NA
PC05	ROM 1	YES	0	173006	OFF	†	OFF	OFF	OFF	OFF	OFF	OFF	ON	ON	012
PC05	ROM 2	NO	0	173204	OFF	†	OFF	ON	OFF	OFF	OFF	OFF	ON	OFF	NA
PC05	ROM 2	YES	0	173206	OFF	†	OFF	ON	OFF	OFF	OFF	OFF	ON	ON	212
PC05	ROM 3	NO	0	173404	OFF	†	ON	OFF	OFF	OFF	OFF	OFF	ON	OFF	NA
PC05	ROM 3	YES	0	173406	OFF	†	ON	OFF	OFF	OFF	OFF	OFF	ON	ON	412
PC05	ROM 4	NO	0	173604	OFF	†	ON	ON	OFF	OFF	OFF	OFF	ON	OFF	NA
PC05	ROM 4	YES	0	173606	OFF	†	ON	ON	OFF	OFF	OFF	OFF	ON	ON	612
LO SPD RDR	ROM 1	NO	0	173034	OFF	†	OFF	OFF	OFF	OFF	ON	ON	ON	OFF	NA
LO SPD RDR	ROM 1	YES	0	173036	OFF	†	OFF	OFF	OFF	OFF	ON	ON	ON	ON	042
LO SPD RDR	ROM 2	NO	0	173234	OFF	†	OFF	ON	OFF	OFF	ON	ON	ON	OFF	NA
LO SPD RDR	ROM 2	YES	0	173236	OFF	†	OFF	ON	OFF	OFF	ON	ON	ON	ON	242
LO SPD RDR	ROM 3	NO	0	173434	OFF	†	ON	OFF	OFF	OFF	ON	ON	ON	OFF	NA
LO SPD RDR	ROM 3	YES	0	173436	OFF	†	ON	OFF	OFF	OFF	ON	ON	ON	ON	442
LO SPD RDR	ROM 4	NO	0	173634	OFF	†	ON	ON	OFF	OFF	ON	ON	ON	OFF	NA
LO SPD RDR	ROM 4	YES	0	173636	OFF	†	ON	ON	OFF	OFF	ON	ON	ON	ON	642

*The starting address for the console load address and start sequence.

† S1-2: when ON, power-up boot is enabled; when OFF, power-up boot disabled. (Must be OFF for PDP-11/60. See PDP-11/60 documentation for power-up boot.)

NOTES

If diagnostics are to be run, a CPU diagnostic ROM must be in location E20, and jumper W8 must be out.

When booting from the console emulator, a device mnemonic and unit number are required. If unit number is not entered, it is assumed to be zero. Listed below are the device mnemonic and unit numbers supported by this ROM, and the device CSR address assumed by the boot code.

Device	Mnemonic	Unit	CSR
HI SPD RDR	PR	N/A	777550
LO SPD RDR	TT	N/A	777560

Table C-10 ROM P/N 23-761A9

Device to be Booted	ROM Location from App B	Diagnostic	Unit	Starting Address*	Switch Settings S1 - for Power-Up Boot or Push-Button Boot of Device										SWR Code
					1	2	3	4	5	6	7	8	9	10	
TU60	ROM 1	NO	0	173004	OFF	†	OFF	OFF	OFF	OFF	OFF	OFF	ON	OFF	NA
TU60	ROM 1	YES	0	173006	OFF	†	OFF	OFF	OFF	OFF	OFF	OFF	ON	ON	012
TU60	ROM 2	NO	0	173204	OFF	†	OFF	ON	OFF	OFF	OFF	OFF	ON	OFF	NA
TU60	ROM 2	YES	0	173206	OFF	†	OFF	ON	OFF	OFF	OFF	OFF	ON	ON	212
TU60	ROM 3	NO	0	173404	OFF	†	ON	OFF	OFF	OFF	OFF	OFF	ON	OFF	NA
TU60	ROM 3	YES	0	173406	OFF	†	ON	OFF	OFF	OFF	OFF	OFF	ON	ON	412
TU60	ROM 4	NO	0	173604	OFF	†	ON	ON	OFF	OFF	OFF	OFF	ON	OFF	NA
TU60	ROM 4	YES	0	173606	OFF	†	ON	ON	OFF	OFF	OFF	OFF	ON	ON	612

*The starting address for the console load address and start sequence.

†S1-2: when ON, power-up boot is enabled; when OFF, power-up boot disabled. (Must be OFF for PDP-11/60. See PDP-11/60 documentation for power-up boot.)

NOTES

If diagnostics are to be run, a CPU diagnostic ROM must be in location E20, and jumper W8 must be out.

When booting from the console emulator, a device mnemonic and unit number are required. If unit number is not entered, it is assumed to be zero. Listed below are the device mnemonic and unit numbers supported by this ROM, and the device CSR address assumed by the boot code.

Device	Mnemonic	Unit	CSR
TU60	CT	0-1	777550

Table C-11 ROM P/N 811A9

Device to be Booted	ROM Location from App B	Diagnostic	Unit	Starting Address*	Switch Settings S1 – for Power-Up Boot or Push-Button Boot of Device										SWR Code
					1	2	3	4	5	6	7	8	9	10	
RX02	ROM 1	NO	0	173004	OFF	†	OFF	OFF	OFF	OFF	OFF	OFF	ON	OFF	NA
RX02	ROM 1	YES	0	173006	OFF	†	OFF	OFF	OFF	OFF	OFF	OFF	ON	ON	012
RX02	ROM 2	NO	0	173204	OFF	†	OFF	ON	OFF	OFF	OFF	OFF	ON	OFF	NA
RX02	ROM 2	YES	0	173206	OFF	†	OFF	ON	OFF	OFF	OFF	OFF	ON	ON	212
RX02	ROM 3	NO	0	173404	OFF	†	ON	OFF	OFF	OFF	OFF	OFF	ON	OFF	NA
RX02	ROM 3	YES	0	173406	OFF	†	ON	OFF	OFF	OFF	OFF	OFF	ON	ON	412
RX02	ROM 4	NO	0	173604	OFF	†	ON	ON	OFF	OFF	OFF	OFF	ON	OFF	NA
RX02	ROM 4	YES	0	173606	OFF	†	ON	ON	OFF	OFF	OFF	OFF	ON	ON	612

*The starting address for the console load address and start sequence.

† S1-2: when ON, power-up boot is enabled; when OFF, power-up boot disabled. (Must be OFF for PDP-11/60. See PDP-11/60 documentation for power-up boot.)

NOTE

If diagnostics are to be run, a CPU diagnostic ROM must be in location E20, and jumper W8 must be out.

When booting from the console emulator, a device mnemonic and unit number are required. If unit number is not entered, it is assumed to be zero. Listed below are the device mnemonic and unit numbers supported by this ROM, and the device CSR address assumed by the boot code.

Device	Mnemonic	Unit	CSR
RX02	DY	0-1	777170

Table C-12 ROM P/N 23-764A9

Device to be Booted	ROM Location from App B	Diagnostic	Unit	Starting Address*	Switch Settings S1-for Power-Up Boot or Push-Button Boot of Device										SWR Code	
					1	2	3	4	5	6	7	8	9	10		
TS04	ROM 1	NO	0	173004	OFF	†	OFF	OFF	OFF	OFF	OFF	OFF	OFF	ON	OFF	NA
TS04	ROM 1	YES	0	173006	OFF	†	OFF	OFF	OFF	OFF	OFF	OFF	OFF	ON	ON	012
TS04	ROM 2	NO	0	173204	OFF	†	OFF	ON	OFF	OFF	OFF	OFF	OFF	ON	OFF	NA
TS04	ROM 2	YES	0	173206	OFF	†	OFF	ON	OFF	OFF	OFF	OFF	OFF	ON	ON	212
TS04	ROM 3	NO	0	173404	OFF	†	ON	OFF	OFF	OFF	OFF	OFF	OFF	ON	OFF	NA
TS04	ROM 3	YES	0	173406	OFF	†	ON	OFF	OFF	OFF	OFF	OFF	OFF	ON	ON	412
TS04	ROM 4	NO	0	173604	OFF	†	ON	ON	OFF	OFF	OFF	OFF	OFF	ON	OFF	NA
TS04	ROM 4	YES	0	173606	OFF	†	ON	ON	OFF	OFF	OFF	OFF	OFF	ON	ON	612

* The starting address for the console load address and start sequence.

†S1-2:when ON, power-up boot is enabled; when OFF, power-up boot disabled. (Must be OFF for PDP-11/60. See PDP-11/60 documentation for power-up boot.)

NOTE

If diagnostics are to be run, a CPU diagnostic ROM must be in location E20, and jumper W8 must be out.

When booting from the console emulator, a device mnemonic and unit number are required. If unit number is not entered, it is assumed to be zero. Listed below are the device mnemonic and unit numbers supported by this ROM, and the device CSR address assumed by the boot code.

Device	Mnemonic	Unit	CSR
TS04	MS	0-3	772520

Table C-13 ROM P/N 23-765A9

Device to be Booted	ROM Location from App B	Diagnostic	Unit	Starting Address*	Switch Settings S1-for Power-Up Boot or Push-Button Boot of Device										SWR Code
					1	2	3	4	5	6	7	8	9	10	
TU58	ROM 1	NO	0	173004	OFF	†	OFF	OFF	OFF	OFF	OFF	OFF	ON	OFF	NA
TU58	ROM 1	YES	0	173006	OFF	†	OFF	OFF	OFF	OFF	OFF	OFF	ON	ON	012
TU58	ROM 2	NO	0	173204	OFF	†	OFF	ON	OFF	OFF	OFF	OFF	ON	OFF	NA
TU58	ROM 2	YES	0	173206	OFF	†	OFF	ON	OFF	OFF	OFF	OFF	ON	ON	212
TU58	ROM 3	NO	0	173404	OFF	†	ON	OFF	OFF	OFF	OFF	OFF	ON	OFF	NA
TU58	ROM 3	YES	0	173406	OFF	†	ON	OFF	OFF	OFF	OFF	OFF	ON	ON	412
TU58	ROM 4	NO	0	173604	OFF	†	ON	ON	OFF	OFF	OFF	OFF	ON	OFF	NA
TU58	ROM 4	YES	0	173606	OFF	†	ON	ON	OFF	OFF	OFF	OFF	ON	ON	612

*The starting address for the console load address and start sequence.

†S1-2: when ON, power-up boot is enabled; when OFF, power-up boot disabled. (Must be OFF for PDP-11/60. See PDP-11/60 documentation for power-up boot.)

NOTE

If diagnostics are to be run, a CPU diagnostic ROM must be in location E20, and jumper W8 must be out.

When booting from the console emulator, a device mnemonic and unit number are required. If unit number is not entered, it is assumed to be zero. Listed below are the device mnemonic and unit numbers supported by this ROM, and the device CSR address assumed by the boot code.

Device	Mnemonic	Unit	CSR
TU58	DD	0-1	776500

APPENDIX D M9312 FASTON TAB CONNECTIONS

D.1 INTRODUCTION

The M9312 Faston tabs are defined in Table D-1. One of the frequent applications of the M9312 is to replace the M9301. Table D-2 provides the necessary information needed to make the appropriate substitutions with respect to the Faston tabs.

Table D-1 Faston Tab Description

Faston Tab	Function Performed
TP1	Boot input
TP2	Return for boot input
TP3	Return for enable boot on power-up
TP4	Enable boot on power-up

Table D-2 Faston Tab Substitution

Wire Connection			
From		To	
Module	Faston Tab	Module	Faston Tab
M9301	TP1	M9312	TP4
M9301	TP2	M9312	TP1
M9301	TP3	M9312	TP2

APPENDIX E

CROSS REFERENCE AND IDENTIFICATION TABLES

E.1 CROSS REFERENCE TABLES

Table E-1 provides a guide used to identify a particular ROM by part number. Table E-2 is a cross reference table which identifies each device with its corresponding controller.

Table E-1 Cross Reference ROM P/N to ROM Table Number

Part Number 23-	Function Performed by ROM				See Table
233F1 248F1	Diagnostic for 11/60/70 ROM ID= B0 ASCII Console and Diagnostic for 11/04/05/34/35/40/45/50/55 ROM ID= A0 The following ROMS are Bootstrap ROMs				F-1 F-2
Bootable Devices					
	Mnemonic	First Device In ROM	Mnemonic	Second Device in ROM	
751A9	DL	RL01	NA	NA	C-1
752A9	DM	RK06/07	NA	NA	C-2
753A9	DX	RX01	NA	NA	C-3
811A9	DY	RX02	NA	NA	C-11
755A9	DP	RP02/03	DB	RP04/5/6 RM02/3	C-4
756A9	DK	RK03/05	DT	TU55/56	C-5
757A9	MM	TU16/E16 TM02/3	NA	NA	C-6
758A9	MT	TU10/TS03	NA	NA	C-7
759A9	DS	RS03/04	NA	NA	C-8
760A9	PR	PC05	TT	LO SPD RDR	C-9
761A9	CT	TU60	NA	NA	C-10
764A9	MS	TS04	NA	NA	C-12
765A9	DD	TU58	NA	NA	C-13

Table E-2 Cross Reference Device to Controller

Device	Controller
RL01	RL11
RK06/07	RK611
RX01	RX11
RX02	RX211
RP02/03	RP11C/E
RP04/05/06 RM02/03	RH11/70
RK03/05	RK11C/D
TU55/56	TC11
TU16/E16 TM02/03	RH11/70
TU10/E10 TS03	TM11/A11/B11
RS03/04	RH11/70
PC05 (HI SPD RDR)	PC11/R11
LO SPD RDR (ASR33)	DL11A/W
TU60	TA11
TS04	TS11
TU58	Serial Line Unit

E.2 ROM IDENTIFICATION

When the ROM configuration of an M9312 already installed in a system is not known, it is desirable to identify the ROM configuration without removing the module. This can be accomplished by running diagnostic CZM9B, or by examining the data in five specific locations and using Table E-3 to identify the ROM. The locations are as follows:

- | | | |
|----|--------|----------------|
| 1. | 765774 | Diagnostic ROM |
| 2. | 773000 | ROM 1 |
| 3. | 773200 | ROM 2 |
| 4. | 773400 | ROM 3 |
| 5. | 773600 | ROM 4 |

By comparing the data observed at the above locations with Table E-3 you can identify the type and location of each ROM in the module.

Table E-3 ROM Identification

Octal Data	Mnemonic	P/N 23-	See Table
040460	A0	248F1	F-2
041060	B0	233F1	F-1
041524	CT	761A9	C-10
042113	CI	761A9	C-10
042113	DK	756A9	C-5
042114	DL	751A9	C-1
042115	DM	752A9	C-2
042120	DP	755A9	C-4
042123	DS	759A9	C-8
042130	DX	753A9	C-3
042131	DY	811A9	C-11
046515	MM	757A9	C-6
046524	MT	758A9	C-7
056122	PB	760A9	C-9
177776	This is a Continuation ROM of a Multiple-ROM Boot		
XXX777	Bad ROM or No ROM Present		
046523	TS04	764A9	C-12
000104	TU58	765A9	C-13

APPENDIX F DIAGNOSTIC AND CONSOLE EMULATOR ROMS

F.1 DIAGNOSTIC ROM (P/N 23-233F1)

There are no special M9312 switch settings that pertain to this ROM. The only way these diagnostics can be executed is by entering a bootstrap at the entry point which calls for diagnostics to be run. This ROM allows the user to boot via the console switch register. This can be done as follows:

1. Load Address 765744.
2. Set switch register according to Table F-1
3. Start.

Table F-1 Console Switch Register Settings for Diagnostic ROM

15	14	13	12	11	10	09	08	07	06	05	04	03	02	01	00
NA	NA	NA	NA												
				Octal Unit Number			SWR Code from Boot ROM Tables								

F.2 CONSOLE EMULATOR AND DIAGNOSTIC ROM (P/N 23-248F1)

This ROM contains an ASCII console emulator routine and diagnostics for use with PDP-11/04, 11/05, 11/34, 11/35, 11/40, 11/45, 11/50, 11/55. To enter the ASCII console via power-up boot or pushbutton boot, the M9312 switches must be set according to Table F-2.

Table F-2 Switch Settings for ASCII Console and Diagnostic ROM

Function to be Booted	ROM Location	Diagnostic	Starting Address*	S1 Switch Settings for Power-Up Boot or Push-Button Boot									
				1	2	3	4	5	6	7	8	9	10
Console Emulator	E20	NO	165144	ON	†	OFF	OFF	ON	ON	OFF	OFF	ON	OFF
Console Emulator	E20	YES	165020	ON	†	OFF	OFF	OFF	OFF	ON	OFF	OFF	OFF

*The starting address for the console load address and start sequence.

†S1-2: When ON, power-up boot is enabled; when OFF, power-up boot is disabled.

Your comments and suggestions will help us in our continuous effort to improve the quality and usefulness of our publications.

What is your general reaction to this manual? In your judgment is it complete, accurate, well organized, well written, etc.? Is it easy to use? _____

What features are most useful? _____

What faults or errors have you found in the manual? _____

Does this manual satisfy the need you think it was intended to satisfy? _____

Does it satisfy *your* needs? _____ Why? _____

Please send me the current copy of the *Technical Documentation Catalog*, which contains information on the remainder of DIGITAL's technical documentation.

Name _____	Street _____
Title _____	City _____
Company _____	State/Country _____
Department _____	Zip _____

Additional copies of this document are available from:

Digital Equipment Corporation
444 Whitney Street
Northboro, Ma 01532
Attention: Communications Services (NR2/M15)
Customer Services Section

Order No. EK-M9312-TM-002

Fold Here

Do Not Tear - Fold Here and Staple

**FIRST CLASS
PERMIT NO. 33
MAYNARD, MASS.**

**BUSINESS REPLY MAIL
NO POSTAGE STAMP NECESSARY IF MAILED IN THE UNITED STATES**

Postage will be paid by:

**Digital Equipment Corporation
Technical Documentation Department
Maynard, Massachusetts 01754**

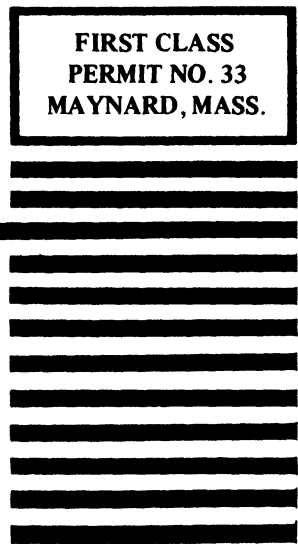

digital

digital equipment corporation